



SoundPath

Subwoofer Isolation System





Thank you, and congratulations on purchasing your new SVS SoundPath Subwoofer Isolation System!

The SVS SoundPath Subwoofer Isolation System decouples and isolates the subwoofer from the flooring, resulting in tighter and cleaner sounding bass, less buzz/rattle in the room, and fewer complaints from adjacent neighbors in apartments and townhouses. It's the next best thing to sound-proofing!

The SoundPath Subwoofer Isolation System works with any brand of subwoofer which accepts screw-in feet. Developed with extensive accelerometer and acoustic measurements, this system features optimized durometer elastomer feet which significantly reduce floor vibration.

Our Sound Experts in Customer Service can assist you with installing the SoundPath Subwoofer Isolation System, so please don't hesitate to contact Customer Service if you need guidance.

If you have any questions about your SVS product, please contact us directly.

www.svsound.com • custservice@svsound.com • (877) 626-5623

TABLE OF CONTENTS

| | |
|--|---|
| PACKAGE CONTENTS..... | 3 |
| INSTALLATION | 4 |
| CABINET / BOX STYLE SUBWOOFERS..... | 4 |
| SVS CYLINDER SUBWOOFERS – BASE PLATE RETAINED..... | 5 |
| SPECIFICATIONS..... | 6 |
| SHARE YOUR THOUGHTS..... | 6 |

PACKAGE CONTENTS

Package Contents:

4 Foot System:

- Four (4) SoundPath Isolation Elastomer Feet with Steel Outer Shell
- Four (4) ¼-20 x 16 mm screws
- Four (4) M6 x 16 mm screws
- Four (4) M8 x 16 mm screws

6 Foot System:

- Six (6) SoundPath Isolation Elastomer Feet with Steel Outer Shell
- Six (6) ¼-20 x 16 mm screws
- Six (6) M6 x 16 mm screws
- Six (6) M8 x 16 mm screws

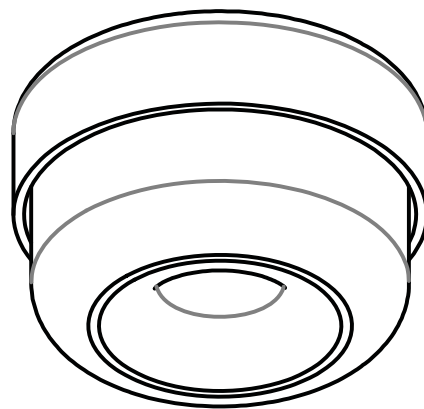
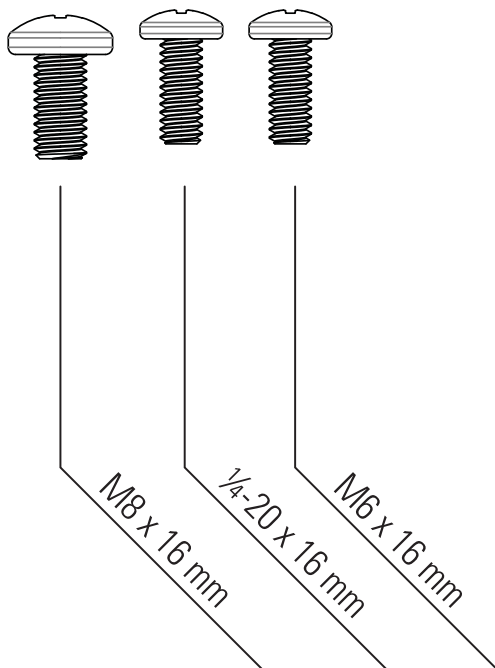

SoundPath Isolation
Elastomer Feet

Cabinet / Box Style Subwoofers:

1. Place padding such as a soft blanket on the flooring to protect the finish of the subwoofer.

2. Using a helper (if needed), carefully place the subwoofer cabinet on its side or top, resting on the blanket. Take care to avoid damaging the amplifier. Important Notice: When moving the subwoofer, do not allow the weight of the cabinet to place an excessive lateral (sideways) load on the feet. This may damage the feet, the threaded insert or the cabinet.

3. Unthread and remove the subwoofer's original equipment (OE) feet.

4. Gather all of the 16 mm long machine screws from the Isolation System kit. There are three (3) thread sizes provided – ¼-20, M6 and M8.

5. Compare the OE feet machine screws to the 16 mm long Isolation System machine screws. Select the matching/correct thread size (SVS cabinet subwoofers utilize the ¼-20 thread size).

6. Once you have selected the correct thread size, install the Isolation feet by inserting the 16 mm long machine screw through the bottom opening of the rubber foot, through the opening in the steel outer shell, and into the threaded insert of the subwoofer cabinet.

7. Make sure the machine screw is correctly aligned and does not cross-thread.

8. Hand-tighten snugly. Avoid over-tightening, which might damage the threaded insert or the cabinet.

9. Using a helper (if needed) carefully lift the subwoofer cabinet and place it directly down onto the installed Isolation feet. Take care to avoid damaging the amplifier.

Important Notice: When placing the subwoofer back into position, do not allow the weight of the cabinet to place an excessive lateral (sideways) load on the Isolation feet. This may damage the Isolation feet, the threaded insert or the cabinet.

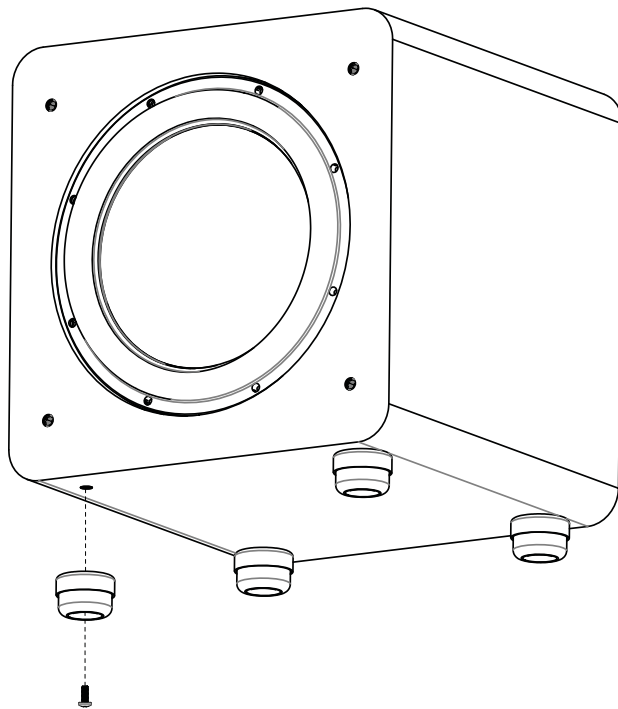

Important Notice: - Do not drag the subwoofer cabinet across the flooring with the Isolation feet installed. This may damage the Isolation feet, the threaded insert or the cabinet. If you need to move the subwoofer, always lift (use a helper if needed) the subwoofer and then place it into the new location.

SVS Cylinder Subwoofers:

1. Using a helper as needed, lay the cylinder subwoofer sideways on a stable surface. Take care to avoid damaging the amplifier.

2. Peel off the original equipment (OE) rubber disc feet.

3. Only remove one (1) OE machine screw at a time.

This will prevent the base plate from dislodging.

Important Notice: - If you are using a powered bit driver to remove and/or install the machine screws, avoid excessive downward pressure on the screw, as that may dislodge the t-nut mounted to the backside of the woofer end-cap.

4. Install the Isolation foot by inserting the OE machine screw through the bottom opening of the rubber foot, through the opening in the steel outer shell, through the base plate, through the dowel (re-aligning the dowel as necessary) and into the t-nut on the backside of the woofer end-cap.

5. Make sure the machine screw is correctly aligned and does not cross-thread.

6. Tighten the OE machine screw avoiding excessive downward pressure. Once the screw fully tightens and starts to pull against the end-cap t-nut, tighten securely using hand-pressure.

7. Using a helper (if needed), carefully stand the cylinder subwoofer back onto the installed Isolation feet. Take care to avoid damaging the amplifier.

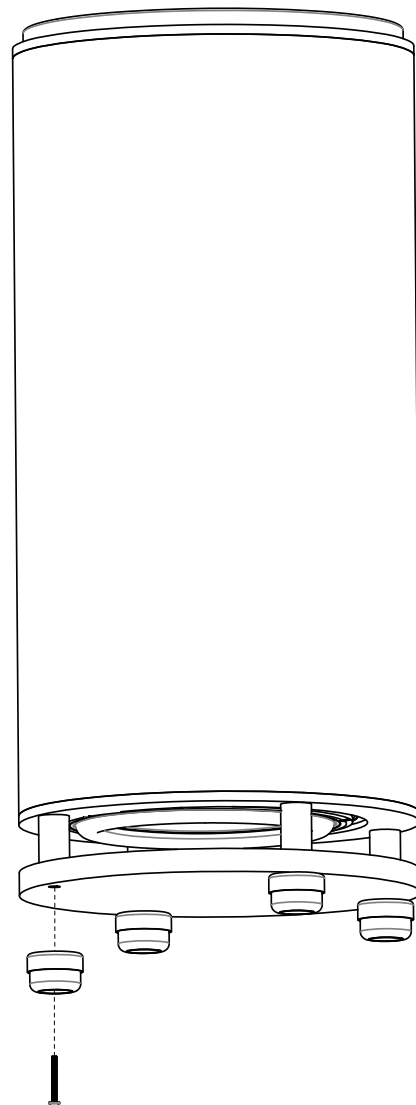

Important Notice: - Do not drag the subwoofer base plate across the flooring with the Isolation feet installed. This may damage the Isolation feet or the base plate. If you need to move the subwoofer, always lift (use a helper if needed) the subwoofer and then place it into the new location.

SPECIFICATIONS

Materials Of Construction:

- Durable Anodized Steel Outer Shell
- Elastomer Foot with Optimized Durometer
- Steel Machine Screws

SoundPath Isolation Feet Dimensions:

- Overall Height: 40 mm
- Shell Diameter: 58 mm
- Foot Diameter: 53 mm
- Screw Engagement Depth: 9 mm (applies to 16 mm length screws)

SHARE YOUR THOUGHTS

Our SVS Sound Experts are standing by from Monday to Friday from 9AM-9PM ET, Saturday from 12PM-6PM, and Sunday from 12PM-4PM to assist you with subwoofer set-up and optimization, AV Receiver settings and more. They can be reached by phone, email or chat via the options below.

www.svsound.com • custservice@svsound.com • (877) 626-5623

We also invite you to share a review on our website and to join our fun and active social media community where we share reviews, featured systems, interesting audio articles and more.



Post at facebook.com/SVSound



Tweet @SVS_Sound



Follow instagram.com/SVS_Sound



SVS
260 Victoria Rd.
Youngstown, Ohio 44515
United States
(877) 626-5623
www.svsound.com