



No loss of fine detail

VIRGO 25^{plus}

Owner's Manual



Contents

Included in the Delivery	page 3
Welcome	page 12
General Tips	page 13
Unpacking and Assembly	page 14-15
Connecting the Loudspeakers / Bi-Wiring Operation	page 16
Setting Up the Loudspeakers	page 17-18
Technical Specifications	page 19



No loss of fine detail

Included in the Delivery

Your new loudspeakers are delivered in two separate boxes. One box contains one loudspeaker and the accessory pack "1", as well as your "Welcome to the Audio Physic Family" package containing this Owner's Manual and the Final Inspection Certificate. In the second box you will find the other loudspeaker and a further accessory pack (number "2").



Box "A"	• "Welcome to the Family" with spirit level to optimise setup			
	• Accessory Pack ("1"):	1x	front grille	
		2x	metal stands	
		4x	decorative caps for the loudspeaker feet	
		1x	mounting set with	4x spikes 4x nuts 4x flange bolts 4x plastic washer 1x Allen key
Box "B"	• Accessory Pack ("2"):	1x	front grille	
		2x	metal stands	
		4x	decorative caps for the loudspeaker feet	
		1x	mounting set with	4x spikes 4x nuts 4x flange bolts 4x plastic washer 1x Allen key

audio physic

No loss of fine detail

Welcome

Dear music lover,

We would like to thank you for putting your trust in our products and welcome you to the family of audiophile friends of AUDIO PHYSIC.

You have chosen a top-class product that has been developed in Germany. We would like to congratulate you on this choice and wish you a lot of fun and enjoyment with your product.

In order to earn your trust, we only use the latest technical expertise and top-quality components when manufacturing our loudspeakers and we produce them in accordance with strict quality criteria. These criteria enable us to provide original owners with a 10 year warranty for our loudspeakers (2 years for the subwoofer electronics and 10 years for the drivers), starting on the date of purchase of the product by the original owner, which is far longer than the legally prescribed warranty periods. In order to secure this additional service, please fill out the warranty card enclosed with your loudspeakers and send this and a copy of your proof of purchase to your AUDIO PHYSIC distributor.

Only after several electronic and acoustic test runs, which our quality assurance staff confirm by signing the enclosed certificate, are our loudspeakers allowed to leave the factory in secure packaging. These measures help to ensure that you can enjoy the full experience of the high-quality materials, production and sound of AUDIO PHYSIC loudspeakers in the comfort of your own home.

As a rule, your competent AUDIO PHYSIC dealer will deliver and install your loudspeakers. If you would rather install your product yourself, the following pages provide you with detailed tips and steps to follow in order to safely set up your loudspeakers. **Have fun with your VIRGO 25^{plus!}**

No loss of fine detail: If you want a close-up first-hand experience of exactly what your new AUDIO PHYSIC loudspeakers can do, we recommend that you try out our Anniversary Sampler CD. These 16 pieces of classical music with flawless quality are bound to put a smile on your face.



audio physic

No loss of fine detail

General Tips

Depending on the size of your loudspeakers, it is a good idea for two people to unpack them. The ideal way to do so is to put the boxes on the floor, **making sure that the product labels are facing up**. Open the packaging carefully and remove the accessory packs from the box. Then work together to attach the foot construction as described in the chapter "Unpacking and Assembly".

The loudspeakers should reach a temperature that is approximately equivalent to room temperature before you connect them to the HiFi system and/or operate them. This instruction predominately refers to the winter months in case the loudspeakers were previously stored in a cold room.

Maintenance

Our loudspeakers are coated in high-quality veneers or high-gloss lacquers. You should avoid using chemical cleaning agents because these can attack the loudspeaker surfaces and make them go matt. As a rule, a fine, soft and damp cloth is all that you need to clean the surfaces. If a cleaning agent is required, use this to dampen the cloth and do not directly apply it to the surface. It is best if you test the suitability of the cleaning agent on a less visible part of the cabinet.

The drivers do not normally need to be cleaned. Dust particles fall off quickly when the loudspeakers are operated. You can, however, carefully clean the drivers with a soft brush. When doing so, please only lightly brush over the surface and do not put any pressure on it. Please **never use any cleaning agents on the drivers**. Do not expose the loudspeakers to direct sunlight. Anodised surfaces are sensitive to acids and alkalis and to ultraviolet light and may fade.

The drivers in this range of AUDIO PHYSIC loudspeakers use a unique mounting technique. Rather than directly mounting the drivers onto the cabinet of the loudspeaker, the drill holes contain special neoprene plugs. These neoprene plugs tighten in the mounting hole when the screws are fitted, creating a permanently elastic connection between the driver and the cabinet that reduces resonance. **You do not need to tighten these screws.** Re-tightening the screws may damage the plugs and have a negative effect on the sound.

Burning in the Loudspeakers

The loudspeakers first reach their full sound potential after a specific burn-in period. We **burn in the drivers at our factory prior to assembly**, meaning that they normally only need a burn-in period of a few hours at a normal room volume and with music that has a range of frequencies that is as wide as possible, for example orchestral pieces. Recordings containing 'white or pink noise' such as those available on many so-called Test CDs are also ideal. **For safety reasons, these pieces should never be played at high volumes.**

Stray Magnetic Fields

The magnetic field created by the individual driver magnets may to some extent have an effect outside of the loudspeaker. This stray magnetic field may interfere with other devices, particularly televisions and monitors with cathode ray tubes (not LCD or plasma televisions), for example by causing changes in colour in the picture. We recommend that you **place the loudspeakers approximately half a metre away from such devices** (and also from magnet tapes, video cassettes, credit cards with magnetic stripes, etc.).

Where possible, **please retain the loudspeaker packaging**. You can then securely transport your loudspeakers if you move house.



No loss of fine detail

Unpacking and Assembly

1. Place the boxes on the floor, making sure that the product labels are facing up. Carefully open the packaging on the long side where it has been taped up, as shown in the illustrations below (illustration similar), preferably using a pocket knife or kitchen knife.



Correct: In order to correctly unpack the loudspeaker, the top of the loudspeaker should be facing down. This means that you will easily be able to hold on to the bottom of the loudspeakers when carefully pulling them out of the box and also enables you to attach the foot construction without difficulty.

False: If the top of the loudspeaker is facing up, you will have to turn the loudspeaker upside down once you have removed it from the box in order to attach the foot construction.

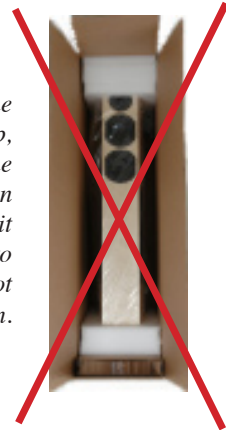

2. Remove the accessory packs from the boxes.
3. Carefully remove the loudspeakers, together with their protective foam pads, from the upright box. It is ideal if two people carry out this step. **Make sure that you do not touch the drivers** when removing and handling the loudspeakers as this may cause irreparable damage to the drivers.
4. Now remove the foam cover from the top and carefully pull down the foil, so that you can easily attach the foot construction.
5. Remove the metal stands from the accessory pack and screw the spikes into the designated inserts.



6. Tighten the lock nuts onto the spikes from above.



7. Now lay the metal stands with the attached spikes on the loudspeaker and adjust the stands so that their screw inserts are aligned with the inserts in the loudspeaker base.

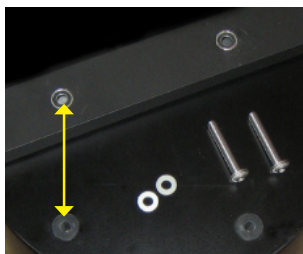

[audio physic]

No loss of fine detail

8. Place the plastic washers included in the delivery onto the bore holes of the stands from above and insert the provided flange bolts into the holes. Tighten the flange bolts firmly. The bolts need **about seven turns** for optimum grip.

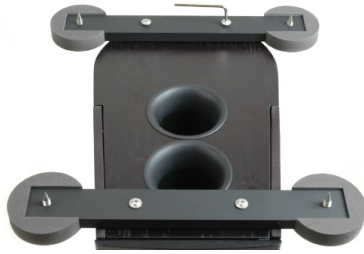

(illustration similar)

9. Now turn over the loudspeakers so that the metal feet are in stable contact with the floor. Two people should also carry out this step where possible. **Make sure that you do not hurt yourself on the tips of the spikes.**
10. Place the loudspeakers in their intended positions and finely adjust the spikes so that the loudspeakers do not wobble. If you do not place the loudspeakers in a secure and stable position and they therefore wobble, this will have a major effect on the sound. When the boxes are standing **level and upright**, you have set them up perfectly. The enclosed spirit level will help you to finely adjust the loudspeakers (they are level when the bubble remains in the inner circle). Use the lock nuts to again tighten the spikes. Roughly hand-tightening the nuts is sufficient.



11. Attach the foot end caps to the feet. The small foam ring secures the decorative cap and ensures that the cap does not resonate when the loudspeaker is operated. Simply lift up the foot end caps to remove them.



You can now start to optimally align your new VIRGO 25^{plus} to the listening position. You can find tips regarding this process in the following chapter on “Setup” and can access particularly detailed information on the AUDIO PHYSIC website.

If you want to increase the sound quality even more in terms of precision and bass response, try out our high-quality VC feet (for example VCF II Double M8 in the image on the right) on your loudspeakers. The “Vibration Control” feet are not only an alternative to spikes for high-quality flooring, but also reduce the transmission of vibrations between the loudspeakers and the floor. This results in an audible improvement to the level of detail and realistic sound reproduction. For more information and advice, please contact your dealer.

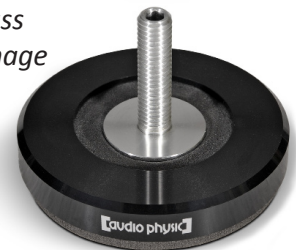

audio physic

No loss of fine detail

Connecting the Loudspeakers

1. Please switch off all equipment in your HiFi system before you begin to connect your loudspeakers.
2. Attach the loudspeaker cable to the connectors on the loudspeakers. When doing so, please make sure that you have the right polarity. As a rule, loudspeaker cables are accordingly labelled, either by a permanent marking on one of the two conductors of the cable or by plus "+" and "-" markings on the cable ends.
3. Now connect the cable to your loudspeaker and make sure that you also have the right polarity here.
4. The VIRGO's connectors, which are shown in the image on the right, accept both spades and banana plugs. Loose cable strands oxidise easily and are not suitable for a permanently high-quality listening experience.



“Bi Wiring“ Operation

If your loudspeaker is fitted with a bi-wiring terminal and you would like to use this option, please connect the loudspeaker cable from the amplifier for the left loudspeaker to the upper two connectors on the left loudspeaker in order to control its midrange area and tweeter system and a further cable to the connectors underneath in order to control the woofer system. Carry out the same steps on the loudspeaker to the right of the listening position. Please remove and retain the respective bi-wire bridges on the loudspeaker terminals before connecting the cables.



A glance into the interior of the Virgo 25^{plus} shows the complex design of the loudspeaker and the ceramic elements (grey) for added rigidity.

audio physic

No loss of fine detail

Setting Up the Loudspeakers

1. The ideal placement of your loudspeakers in your room involves positioning them in an isosceles triangle arrangement including your listening seat, creating equal spacing between each loudspeaker and the listening position.
2. The distance between the loudspeakers should be around 0.8 - 1.2 times as much as the distance between the loudspeakers and the listening position. The closer you sit to the loudspeakers, the more direct and dry your sound experience will be. As you move further away from the loudspeakers, the bass response will normally increase and the spatial imaging will seem more generous.
3. Where possible, the loudspeakers should be positioned half a metre away from the surrounding walls. The larger the space between the loudspeakers and back wall, the more

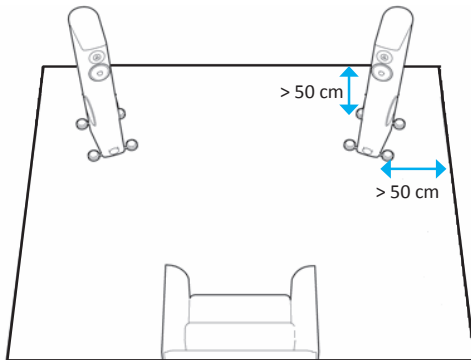

precise the sound reproduction, particularly where bass frequencies are concerned.

Setup away from the wall: The loudspeakers are positioned at least 50 centimetres away from the surrounding walls.

4. The closer the loudspeakers come to the back wall (and/or side wall), the more powerful the broadband reproduction of the low frequencies will be resulting in stronger bass tones.

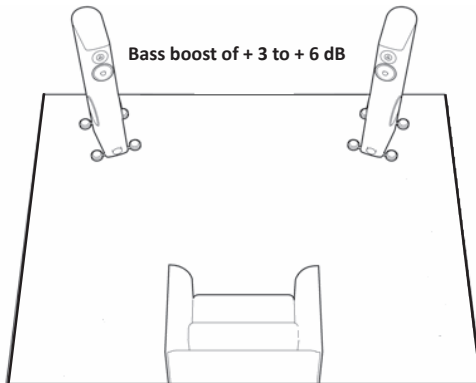

This bass boost can, however, also result in a sound reproduction that is undifferentiated and lacking in detail, depending on how close the loudspeakers are to the walls.

Setup close to the wall: Low frequencies are broadly reinforced by around +3 and +6 decibels when the loudspeakers are positioned close to the wall.

5. This effect can be made even more intense when the loudspeakers are placed in a corner. Low tones become around 6 decibels (or more) louder and have a major effect on the sound

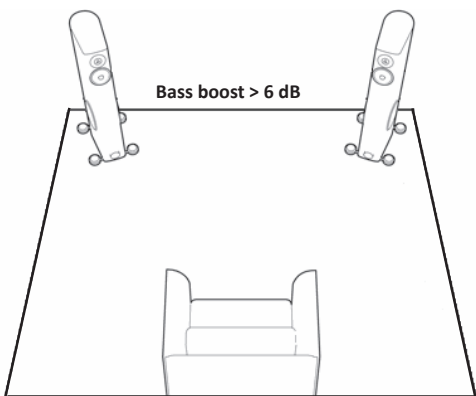

reproduction. Where possible, you should not place your new loudspeakers in a corner because the acoustic conditions in this position do not allow them to display their full range of sound reproduction possibilities, instead they will stay far below their actual sound potential.

Setup in the corners of the room: Low tones become significantly louder and overlap into the midrange frequencies. This results in a washed-out and lethargic sound reproduction.

audio physic

No loss of fine detail

- Alongside the strength of the bass response, the distance from the side walls also particularly affects the localisation of sound events and therefore the precision of the spatial imaging. As the distance from the walls increases, the localisation will become more precise and the sound will be more balanced. When the loudspeakers are extremely close to the side walls, this will result in early acoustic reflections, leading to both reduced spatial perception and a rather nervous sound reproduction. Curtains or shelves or similar at the sides reduce this effect.

Positioning the Loudspeakers

- Once the loudspeakers are positioned parallel to the side walls, turn them inwards until an imaginary line is pointing from the tweeter of each loudspeaker towards your preferred listening position. If you prefer to listen to music alone, these imaginary lines coming from the loudspeakers should 'intersect' at your listening position. This will result in excellent localisation and spatial imaging. If you would rather listen to music in a group, turn the loudspeakers further inwards so that the imaginary lines cross in front of the listening position.

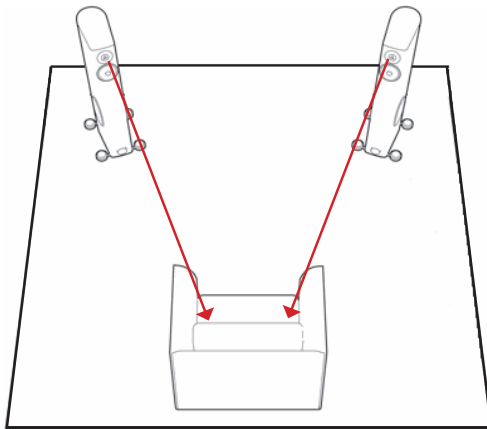

First Step: Angle the loudspeakers so that an imaginary line is in place between the tweeters and your listening position.

- If you prefer a wider soundstage and more generous spatial imaging, position the loudspeakers at less of an angle so that the imaginary lines cross just behind the listening position. Once a specific angle has been reached, the spatial image in the centre between the loudspeakers will begin to lose structure and precision. You can easily identify the ideal angle by using a mono recording. When the voice of the artist sounds clear again and comes directly from the middle between the loudspeakers, you have found the ideal position.

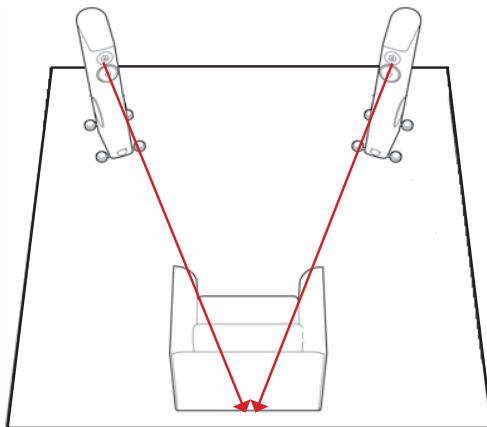

Second Step: Experiment with the angle. When it comes to positioning your loudspeakers, your listening taste plays an important role. To find the ideal position, mono recordings are extremely useful, particularly those with a singing voice and few instruments.

You can find an abundance of further tips concerning setting up your speakers and background information on the topic of listening in the technical area of our website at: www.audiophysic.de

Technical Specifications

Height	41.5"
Width	9.1"
Depth	15.7"
Required Space: Width x Depth	14.7" x 18.5"
Weight	71 lbs. each
Recommended amplifier power	30 - 180 watts
Impedance	4 Ohm
Frequency range	30 Hz - 40 kHz
Sensitivity	89 dB
Loudspeaker systems	
Woofer	2 x 7"
Midrange	1 x 5.9" / HHCM
Tweeter	1 x 1.75" / HHCT-II

VIRGO 25^{plus}**audio physic***No loss of fine detail*



AUDIO PHYSIC GmbH
Almerfeldweg 38
59929 Brilon / Deutschland
Germany
Tel. +49(0)2961/9617-0; Fax +49(0)2961/51640
info@audiophysic.de / www.audiophysic.de

Distributed in North America by:
VANA, Ltd.
2845 Middle Country Road Lake
Grove, NY 11755 (631)
246-4412.
www.vanald.com

[audio physic]

No loss of fine detail