



Owners Manual For The
Metro XD
Subwoofer System

Table of Contents

	Page
Registration	
Owners Record	3
The Cabinetry / Our Commitment	4
Warranty	5
Setup	
Unpacking Your Speakers	6
Speaker Placement	7-8
Speaker Connections	9-11
Fine Tuning	12-13
Designer Notes	
Room Resonances	14
Subwoofer Boundary Reinforcement: Corner Placement	15
Technology	
Specifications	16

Owners Record

Thank you for selecting a Legacy subwoofer. This handcrafted instrument will provide you with many years of listening enjoyment.

The serial number is located on the rear of the unit. Record this number in the space provided below. Refer to this when calling your dealer regarding this product.

Model: Metro XD

Serial No: _____

Date of purchase: _____

Register your product at legacyaudio.com/register

Share your Legacy speakers with the Legacy community. Post your Legacy experience and system photos at facebook.com/LegacyAudio. Like the page to continue receiving the latest Legacy announcements.

The Cabinetry / Our Commitment

Handcrafted

Beneath the surface of Metro XD's elegant exterior lies rigid MDF construction. Interlocking joinery maximizes the strength of the cabinet parts.

Each cabinet is impeccably finished on all exposed surfaces with select veneers. The exquisite finish is hand-rubbed several times to assure a patina at home with the most elegant decor.

Our Commitment

A great deal of forethought, love and satisfaction is instilled in each piece of Legacy workmanship. We take pride in getting to know many of our customers on a first name basis.

Your purchase of this product is backed by the renowned Legacy warranty.

Warranty

Legacy Audio supports its customers and products with pride. We cheerfully warrant our loudspeaker products we manufacture from defects in materials and workmanship for a period of seven (7) years. Electronic components such as internal amplifiers and digital processors are covered for three (3) years. Please register your product with Legacy Audio. Should you require service Legacy will require a proof of purchase in order to honor the warranty - so please keep your receipt.

- The warranty applies to the original owner and is not transferable.
- The warranty applies to products purchased from an “Authorized Legacy Dealer”.
- The warranty on active components such as digital processors or internal amplifiers is limited to three (3) years of coverage.
- The warranty on dealer stock will extend for a maximum of two years from invoice.

The warranty does not cover transportation costs of product to or from the customer, distributor or dealer, or related shipping damage.

Exclusions from Warranty

The following situations or conditions are not covered by the Legacy Audio warranty:

- Accidental damage, electrical abuse (such as burnt or jammed voice-coils) or associated equipment failure.
- Use inconsistent with recommended operating instructions and specifications
- Damage caused by modification or unauthorized service
- Costs associated with the removal and reinstallation of defective products. Consequential damage to other products.
- Normal wear such as fading of finishes due to sunlight.

Unpacking Your Speakers

Your new subwoofer has been very carefully packaged to insure that it travels to you safely. Each subwoofer is protected by a double-wall outer carton with heavy V-board corner protectors. Custom fitted foam end caps are used to protect the elegant cabinetry, and a custom bag is included to provide further protection. Please save this packing for future transportation. If cartons become damaged or misplaced, new ones can be purchased from Legacy Audio.

Speaker Placement

Since the human ear is rather poor at localizing radiation frequencies below 125 Hz, good results may be obtained in a variety of room placements. Careful adjustment of the convenient panel controls will lead to seamless transition.

Low frequency reinforcement occurs whenever woofers are placed near room boundaries. The distance from the walls, floor and ceiling correspond to the wavelengths of the frequencies which will reflect IN-PHASE and thus reinforce bass output. Therefore, the actual dimensions of your listening room play a definite role in what ultimately arrives at your ear.

We can calculate what the most strongly reinforced frequencies in a room will be by the formula shown below:

$$\text{Resonant Frequency} = (1130 \text{ ft/sec}) / (\text{ft. between boundaries} \times 2)$$

For example, a room with an 8 ft. ceiling height has a strong resonance at:
 $(1130 \text{ ft/sec.}) / (8 \text{ ft.} \times 2) = 71 \text{ Hz.}$

Speaker Placement

Now, while such reinforcement might actually be beneficial at very low frequencies, excessive excitation can cause “overhang” or a droning effect at mid-bass frequencies. A way to minimize excitation of these resonances is to place your subwoofer asymmetrically relative to room boundaries. For instance, if the subwoofer is 2 ft from one corner wall, then place it 1.5 ft to 3 ft from the other.

Placing the subwoofer in a corner will reduce the radiation angle and thus increase efficiency. It will also excite the maximum number of room modes and decrease distortion.

A best case scenario is to actually use two subwoofers, one to each side of the listener. The subs should be placed 90° out of phase with each other. This improves spaciousness and bass uniformity, with a reduction in room level peaks.

Speaker Connections

Once you've found a place in your room, the next step is connecting the Metro XD to your existing system. Listed below you will find 3 options.

Option 1: Connecting the Metro XD using the stereo Low Level preamp/processor inputs.

NOTE: if using the low-level inputs, we suggest using cables that are no longer than 5 meters. Longer lengths of RCA cable can result in greater noise and attenuation of the signal.

If using Left/Right output jacks from the preamp, the internal circuit module of the Metro XD will sum the two channels together. When using the left and right low level inputs on the subwoofer, the internal crossover of the subwoofer is being used. The crossover frequency and level will be controlled by the appropriately labeled controls on the rear panel of the sub.

Option 2: Connecting single sub out

Connect the preamp/processor's "sub out" to the left channel RCA input (mono).

Option 3: The Metro XD provides an XLR input jack for balanced connections from your preamp or processor

Speaker Connections

Powering Up Metro XD

1. Power Cable: The supplied power cable will plug into the socket on the back terminal plate of the unit.

NOTE: Try to plug into the same AC circuit as the rest of your audio system, as this will avoid hum from ground loops.

2. Power Up: On the rear of the subwoofer adjacent to the power cable socket on the back panel is the power switch. This switch controls current flow to the entire unit as follows:

I = Auto On

0 = Off

Fine Tuning



Adjusting the Metro XD Subwoofer

On the back panel of the Metro XD Subwoofer you'll notice four controls: Level, Freq., Blend and Phase. These allow an extraordinary amount of control over your subwoofer. These controls will allow you to tailor the sound of the sub to your room and integrate with your main speakers.

Level (Min/Max): This will allow you to adjust the output volume of the subwoofer.

When using a theater processor, the level & crossover frequency can be controlled remotely with the subwoofer level control knob left at the 3 o'clock position.

Freq.: This control selects the range of low frequency content that will be reproduced. The crossover filter can be varied to pass frequencies below 40Hz and up to 150 Hz.

Fine Tuning

Blend: Turning the knob counter-clockwise reduces energy from the subwoofer in the range of 35-50 Hz. Turning the knob clockwise will increase gain in this area. This can reduce excessive energy or give more low frequency impact in this range depending on the setting. This control is very similar to that of a graphic EQ. The 3 o'clock position is neutral. The center frequency of this control has been carefully chosen to match the first cancellation node of most rooms.

Phase (0 °/-180 °): This control is essential in the proper setup of your subwoofer. If not set up properly, your main speakers and subwoofer can actually work against each other. If operating out-of-phase the subwoofer and mains will cancel, creating nulls at some frequencies (primarily upper bass). What is desirable is to have the subwoofer and the mains operating in phase, relative to the primary listening position. Here is an effective method of accomplishing this:

While seated at your listening position, have someone sweep the phase control slowly from one extreme to the other.

Using pink noise or a 50-60 Hz test tone, listen for the strongest output. Now take note of that setting. Next, play music program material and optimize the level and phase settings further; adjusting for the smoothest output.

Designer Notes: Room Resonances

*The following information is not essential to operating your subwoofer but is provided for enthusiasts who wish to further their understanding.

Three types of acoustical resonances occur in all bounded (non-anechoic) listening environments; tangential, oblique, and axial. Simple axial resonances occur directly between 2 parallel boundaries and have very strong impact on the pressure response in a room. Peaks as great as 6dB, with dips averaging -15 to -45dB occur in most rooms. Troublesome dips as great as -60dB can occur in poorly designed acoustical environments. Resonances cannot be equalized away, as they are positionally dependent. Boosting power to compensate a node will add overwhelming output at the complimentary anti-node.

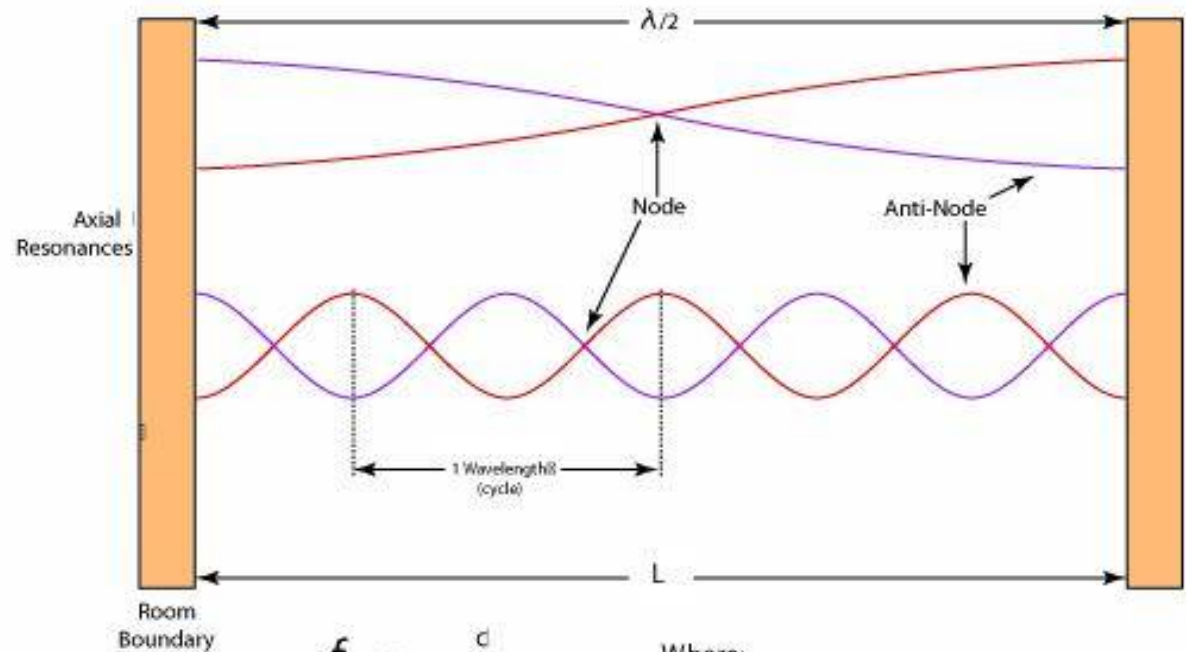

$$f_{res} = \frac{c}{2nL}$$

Where;

c = velocity of sound in air

L = distance between 2 fixed parallel boundaries

f_{res} = frequency that resonance occurs

n = integer; 1, 2, 3...

$$f_{res} = \frac{1,130 \text{ ft/sec.}}{(2) (1) (30 \text{ ft})}$$

Example: L = 30 ft.

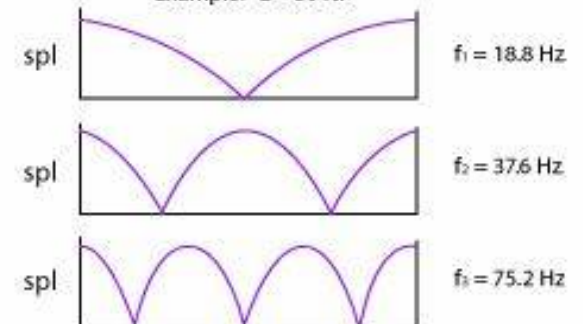

Designer Notes: Subwoofer Boundary Reinforcement

Corner Placement

The plots to the right summarize the boundary influences on a corner placed subwoofer. Shown are frequency response effects for a cubical room (Least Optimal) compared to a room with "Golden" ratios (Most Optimal).

The top graph demonstrates the strong cancellation caused by excessive architectural symmetry. Note 9dB of gain below $K=0.2$ followed by a large energy suck-out between $K=0.2$ and $K=0.4$. This cancellation notch is more than 11 dB deep and an octave wide.

The lower graph represents the same dimensional ratios found in classic architecture such as the Greek Parthenon. Note again, 9dB of low frequency gain is realized but with less than +/-1dB of ripple above $K=1.2$.

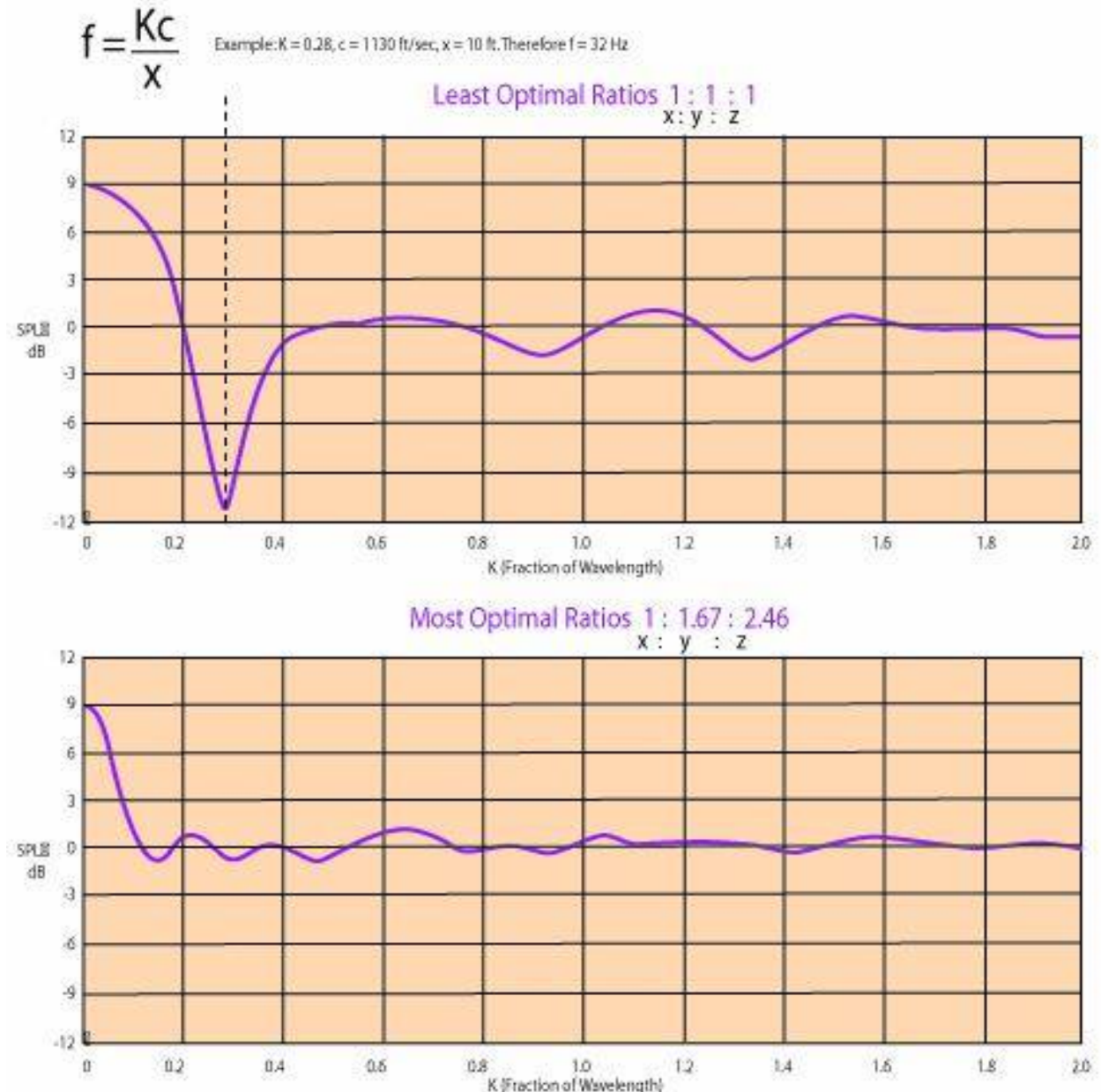

Specifications

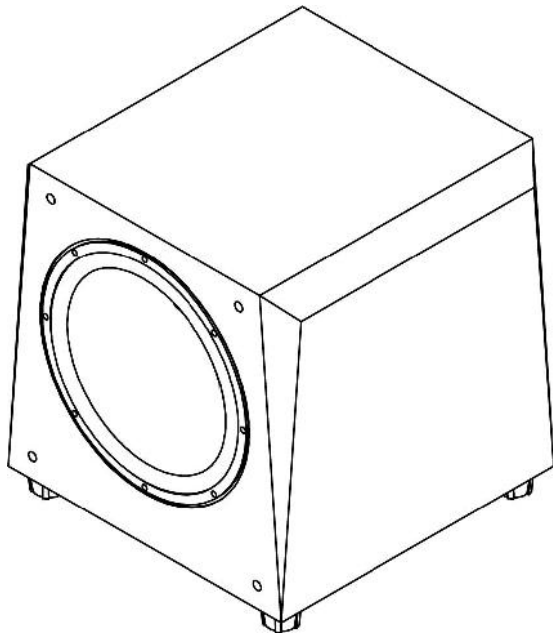
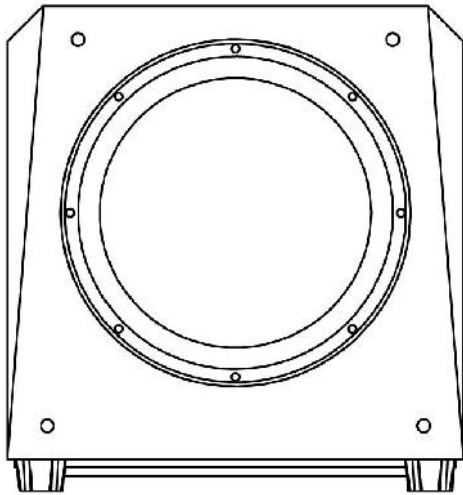

System Type:	Subwoofer, pneumatically coupled
Subwoofer:	12" spun aluminum diaphragm, 480oz motor structure, cast frame, 3" dual 4 layer voice coil
Sub-Bass Radiator:	15" mass loaded down firing
Low Frequency Alignment:	6th Order
Internal Amplification:	750w, Class D ICEpower
Freq. Response (Hz, +/-2dB):	20-150
Impedance:	10k
Phase Adjustment:	Cont. +/-180
Blend EQ:	Level Control
Max. SPL:	118dB @ 1m
Low Pass Filter Slope:	18 dB per octave
Crossover Hz:	40-150
Inputs:	2 RCA, 1 pair high level
Cabinet Dimensions (in):	16 x 16 x 16
Shipping Dimensions (in):	22.63 x 22.5 x 21.75
Cabinet Weight:	68 lbs
Shipping Weight:	123 lbs

CE Declaration of Conformity

Legacy Audio

3023 E. Sangamon Ave.
Springfield, IL 62702 USA
800-283-4644

States that this product is in conformity with the with the essential requirements and other relevant provisions of:

Low Voltage Directive 2006/95/EC
EMC Directive 2004/108/EC



All information contained in this manual is accurate to the best of our knowledge at the time of publication. In keeping with our policy of ongoing product improvement, we reserve the right to make changes to the design and features of our products without prior notice.

WEEE Compliance

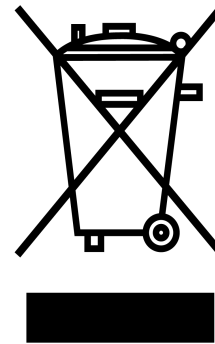

Product Disposal—
Certain international, national and/or local laws and/or regulations may apply regarding the disposal of this product. For further detailed information, please contact the retailer where you purchased this product or the Legacy Audio Distributor in your country. A listing of Legacy Audio Distributors can be found on the Legacy Audio website www.legacyaudio.com or by contacting Legacy Audio at: 3023 E. Sangamon Ave., Springfield, IL 62702, USA—
Phone: +1 217 544-3178.

Notes:



©2017 Legacy Audio
3023 E Sangamon Ave.
Springfield, IL 62702
Phone: 800-283-4644
Fax: 217-544-1483