



Owners Manual For The  
**Silhouette**  
Loudspeaker System



---

# Table of Contents

Registration	Page
Owners Record	3
The Cabinetry / Our Commitment	4
Warranty	5
Setup	
Speaker Installation	6
Silhouette On Wall Installation	7
Silhouette Pro On Wall Installation	8
Silhouette Pro In Wall Installation	9
Hooking Up Cables	10-11
Amplification	12-14
Speaker Connections	15
Technology	
Developing a Reference Class On-Wall	16-19
Specifications	20

---

## Owners Record

Thank you for selecting a Legacy Loudspeaker System. These hand-crafted instruments will provide you with many years of listening enjoyment.

Share your Legacy speakers with the Legacy community. Post your Legacy experience and system photos at [facebook.com/LegacyAudio](https://facebook.com/LegacyAudio)  
Like the page to continue receiving the latest Legacy announcements.

The serial number is located on the rear of the unit. Record this number in the space provided below. Refer to this when calling your dealer regarding this product.

Model: Silhouette

Serial No: \_\_\_\_\_

Date of purchase: \_\_\_\_\_

---

# The Cabinetry / Our Commitment

## **Handcrafted**

Beneath the surface of Silhouette's elegant exterior lies rigid MDF construction. Interlocking joinery maximizes the strength of the cabinet parts. Polyester fiberfill is selected for internal damping. A sharp rap on the enclosure will leave you with little more than bruised knuckles.

Each cabinet is impeccably finished on all exposed surfaces with select veneers. The exquisite finish is hand-rubbed several times to assure a patina at home with the most elegant decor.

## **Our Commitment**

A great deal of forethought, love and satisfaction is instilled in each piece of Legacy workmanship. We take pride in getting to know many of our customers on a first name basis.

Your purchase of this product is backed by the renowned "Legacy Satisfaction Guarantee".

---

# Warranty

Legacy Audio supports its customers and products with pride. We cheerfully warrant our loud-speaker products we manufacture from defects in materials and workmanship for a period of seven (7) years. Electronic components such as internal amplifiers and digital processors are covered for three (3) years. Please register your product with Legacy Audio. Should you require service Legacy will require a proof of purchase in order to honor the warranty - so please keep your receipt.

- The warranty applies to the original owner and is not transferable.
- The warranty applies to products purchased from an "Authorized Legacy Dealer".
- The warranty on active components such as digital processors or internal amplifiers is limited to three (3) years of coverage.
- The warranty on dealer stock will extend for a maximum of two years from invoice.

The warranty does not cover transportation costs of product to or from the customer, distributor or dealer, or related shipping damage.

## **Exclusions from Warranty**

The following situations or conditions are not covered by the Legacy Audio warranty:

- Accidental damage, electrical abuse or associated equipment failure.
- Use inconsistent with recommended operating instructions and specifications
- Damage caused by modification or unauthorized service
- Costs associated with the removal and reinstallation of defective products. Consequential damage to other products.
- Normal wear such as fading of finishes due to sunlight.

---

# Speaker Installation

Select the wall locations for the Silhouette system. Try to create a 60 degree angle horizontally between the speaker pair, relative to the listening position. This usually results in a 10 foot horizontal spread between the speakers, center to center. Recommended mounting height for the loudspeaker puts the wall bracket screw holes at 61.5" off the floor. This may be adjusted slightly to accommodate the sight lines of the monitor."

## Precautions

If you have any doubts about your ability to properly install in/on-wall loudspeakers, you should consider the services of a custom installer. If you plan to install them yourself, always use high quality tools to save time and make the installation go more smoothly. Determine the final location of both left and right speakers before drilling or cutting any holes since changes to one speaker may affect the other either aesthetically or acoustically. Look for pipes, wiring or any other conflicting material that might be damaged before beginning the installation.

There are several ways to install Silhouette, depending on which version you are using.

Silhouette On Wall Installation: Page 7

Silhouette Pro On Wall Installation: Page 8

Silhouette Pro In Wall Installation: Page 9

# Silhouette On Wall Installation

The Silhouette is provided with a pre-installed solid aluminum wall bracket. Locate the desired height for the top of the speaker with the lower edge of a piece of masking tape on the wall. Now measure downward 11 inches. This is the height that the provided bracket will need to have the two mounting screws installed.

Once this height is determined, use a level to set the bracket position and mark two holes locations onto the wall. The grooves in the bracket should be against the wall and oriented down as illustrated.

If the hole locations do not coincide with wall studs, use the included plastic wall inserts. These threaded inserts do not tear out as a molybolt or expanded inserts can. Screw the inserts into the drywall until flush (*do not strip by overtightening*). Now attach the bracket with the provided screws.

When sliding the Silhouette onto the wall bracket start with the top of the speaker an inch or two above your tape mark, pressed gently against the wall and lower down slowly. Do not let go of the speaker until you are certain it is fully locked into the wall bracket.

**Required**  
Two people  
Compact level  
Powered phillips driver  
Masking tape or pencil  
1/8" bit for pilot holes



Provided screws must be threaded fully into studs or provided wall inserts

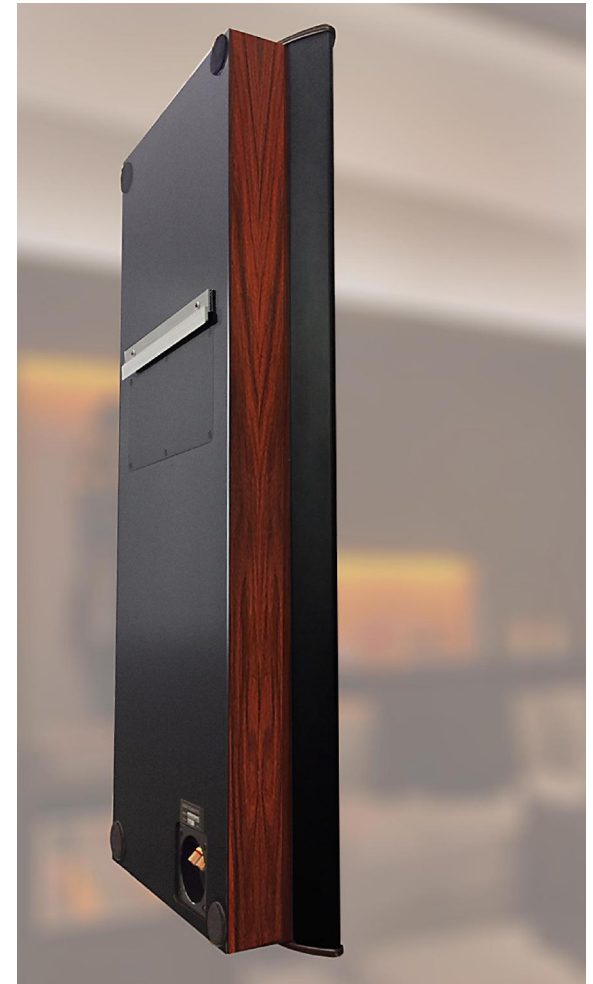
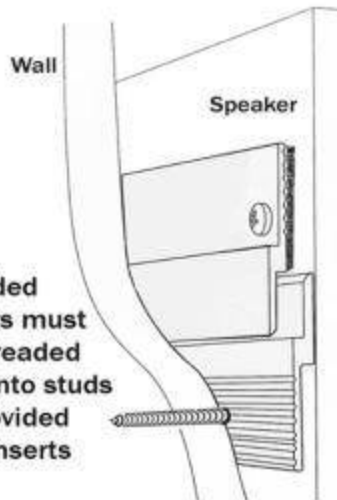

# Silhouette Pro On Wall Installation

When mounting Silhouette Pro flat on the wall, use the included pair of Z- Clips as shown with the longer bar clip anchored to wall studs.

## Silhouette Pro Rear

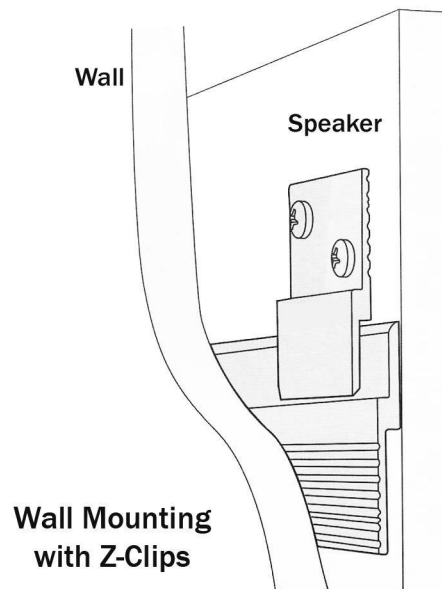



# In Wall Installation of Silhouette Pro

Studs shown are standard 16" center to center

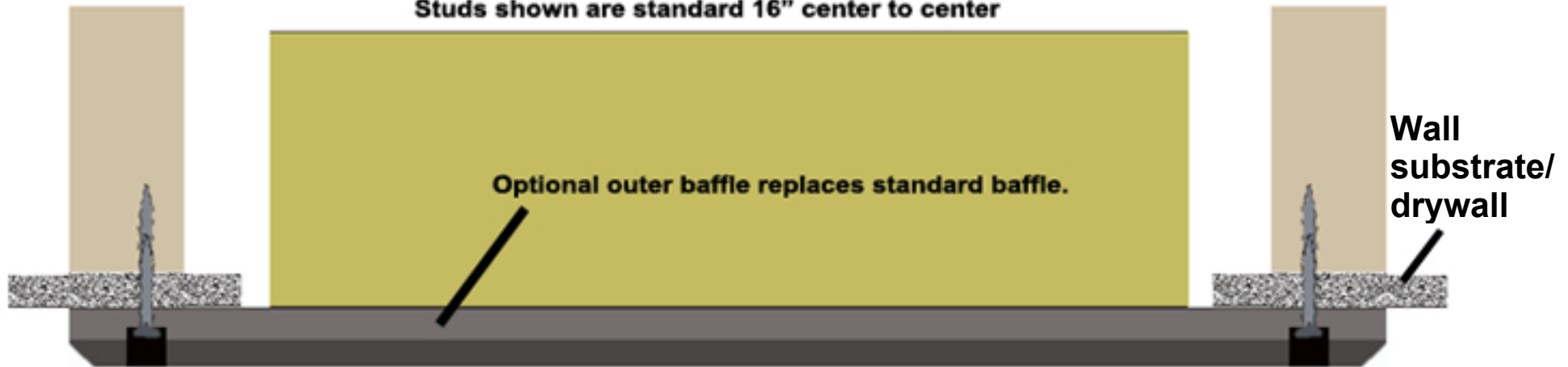

Silhouette Pro can be ordered with an oversized outer baffle to allow in-wall installation.

The outer baffle is 37" long and 18.5" wide. Six mounting screws are to be installed through the center of the grille cups into the wall framing.

Care should be taken to avoid electrical or plumbing before cutting into wall or installing screws into studs.

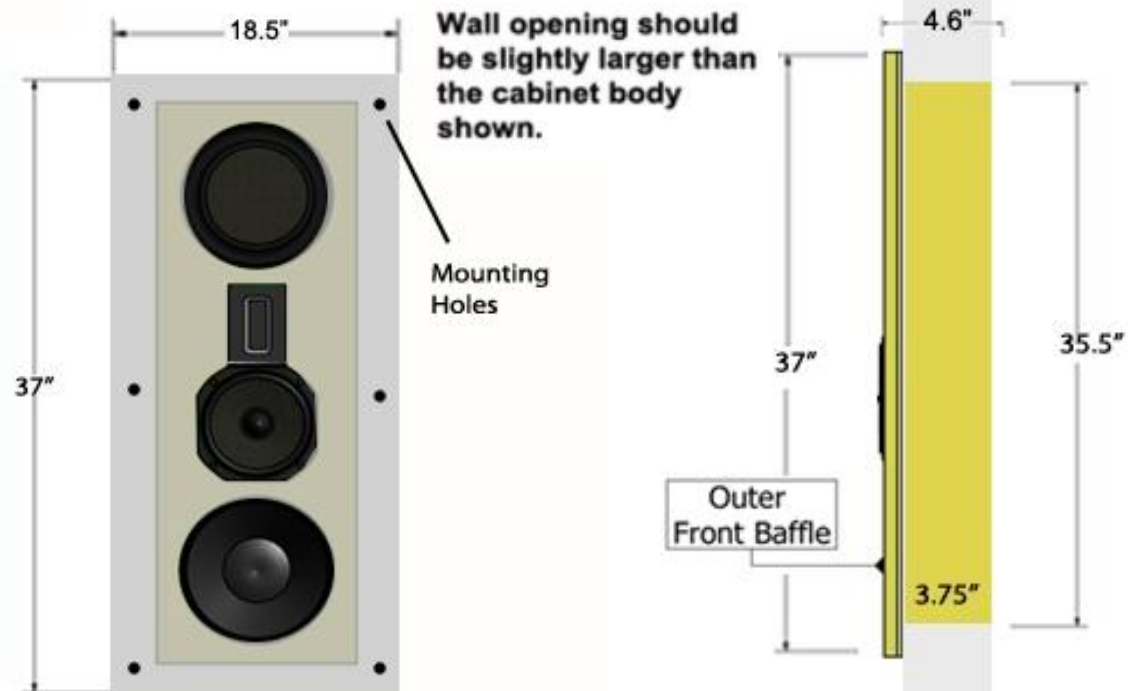

---

# Hooking Up Cables

The ideal conductor would have negligible resistance, inductance and capacitance. The table below shows how a few actual speaker cables measure up.

Cable	$\Omega$ s/ft	pF/ft	$\mu$ H/ft
12 ga.	0.0033	24	0.21
14 ga.	0.0048	17	0.13
16 ga.	0.0079	16	0.18
18 ga.	0.0128	28	0.21

Capacitance is considered insignificant in each cable because its effect is well out of the audio bandwidth; inductance can be decreased (at the expense of increased capacitance) by keeping the conductor pair closely spaced.

How long would a cable have to be before inductance effects would impinge on the audio spectrum? Approximately 300 feet of 12 gauge would be required to establish a corner frequency of 20 kHz with an 8 Ohm loudspeaker. As you see, inductance is not a problem for most of us.



---

# Hooking Up Cables

What about phase shift due to frequency dependent travel times down the speaker cable? Measurements show that 100 Hz waves will be delayed about 20 billionths of a second behind 10 kHz waves when traveling to the end of a 10 foot speaker cable. Since the cilia of the ear requires 25,000 times longer than this just to transmit phase information, phase shifting is obviously not the primary concern when considering speaker cables.

What about resistance? Finally we are getting somewhere. Resistance is the controlling factor of the amplifier/loudspeaker interface. Excessive resistance can cause major shifts of speaker crossover frequencies. The lower the impedance of the loudspeaker, the greater the effects of series resistance. A 20 foot run of 18 gauge cable can cause up to 10% deviations of crossover center frequencies. That same 20 feet can un-damp your damping factor and reduce your systems' output by one half decibel.

In summary, there are no perfect cables. The best way to approximate the ideal would be to keep loudspeaker leads as short as is practical.

---

# Amplification

Ideally the loudspeaker would be among the first components selected when assembling a playback system. This would allow the user to choose an amplifier capable of delivering adequate amounts of current into the frequency dependent load presented by the loudspeaker. However, when upgrading a system, audiophiles may find themselves matching their new loudspeakers to their existing amplification. For this reason, extensive measures have been taken to ensure that each Legacy speaker system represents a smooth, non-reactive load to virtually any amplifier.

Often there is much confusion regarding amplification and loudness levels. It should be understood that the role of the amplifier goes beyond that of driving loudspeakers to a given sound pressure level. The amplifier should be able to CONTROL the loudspeakers across the entire music spectrum. This means that parameters such as damping factor (values greater than 60 are acceptable) and dynamic headroom should not be overlooked when comparing amplifiers.



---

# Amplification

How much power will your new speakers need? That ultimately depends on your listening environment and musical tastes. As little as five watts per channel should drive them to a level satisfactory for background music. A typical 45 watt per channel receiver may fill a room with the compressed mid-band energy of "heavy metal," but seem to lack weight or control with classical recordings. Some audiophiles feel that 200 watts per channel is the bare minimum to avoid audible clipping distortion when reproducing music at "live" playback levels. Your Legacy speakers are designed to take advantage of "high-powered" amplifiers, so don't be afraid to put them through their paces.

How much is too much power? Rarely is a drive unit damaged by large doses of music power. More often than not the villain is amplifier clipping distortion. Even through decades of refinement, loudspeakers are still notoriously inefficient transducers, requiring huge amounts of power to recreate the impact of the live performance. Typically less than 1% of electrical power is converted into acoustic output. (For example, an omnidirectional transducer with an anechoic sensitivity of 90 dB @ 1w/1m has a full space efficiency of only 0.63%)

---

# Amplification



When an amplifier is unable to fulfill your loudspeakers demands, a damaging harmonic spike may be leaked to the high frequency drivers.

Another important point regarding loudness is that the dB scale is a logarithmic one. This means that a 150 Watt amplifier will potentially sound only twice as loud as a 15 Watt amplifier. If all of this discussion of power and loudness seems a bit abstract, consider the example below.

*The average acoustical power developed by a person speaking in a conversational tone corresponds to a mere 0.00001 Watts. The power that would be developed by the entire population of the city of New York speaking at once would barely illuminate a single 100 Watt light bulb.*

---

# Speaker Connections

## The Terminal Plate

At the rear of each of your Silhouette loudspeakers you will find a terminal plate housing one pair of binding posts.

Hook the high level speaker inputs from the main amplifier to the pair of binding post. Be sure that you observe polarity when making the connections. The positive (+) terminal of the amplifier should be connected to the positive terminal of the loudspeaker. The negative (-) terminal of the amplifier should be connected to the negative terminal of the loudspeaker.

---

## Developing a Reference Class On-Wall

Wall speakers are typically utilitarian. Limited by their placement, physical size and build quality, the sonic results of wall speakers usually qualify them as restricted range surround channels or background music.

As professional studios became more compact with modern digital workstations, we began getting requests for reference grade monitors that could be placed flat against walls. They needed to be as dynamic as premium floor monitors, low in and profile, and fire above the workstation desktop height.

The development of the Silhouette speaker required a new 10" bass driver with a powerful motor design, yet only 3.5 inches of total depth. A rugged new 10" passive radiator with compliance optimized to extend response in the compact enclosure. The 4"AMT ribbon and the 7" silver/graphite midrange/midbass is the same used in several of our towers such as Focus SE and the Signature SE.

The key to this three-way is the crossover frequency between the 10" and 7" is established precisely where the wall dip occurs when a woofer is boundary plane mounted. The dip is the result of an out of phase relationship at that frequency between driver and boundary. The next page shows a simple illustration of the adverse effects of a single near boundary.



# Developing a Reference Class On-Wall

INFLUENCE OF A SINGLE BOUNDARY ON A MONOPOLE

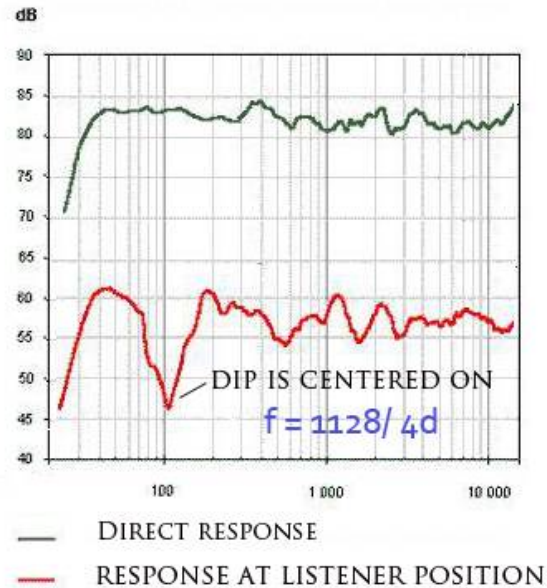
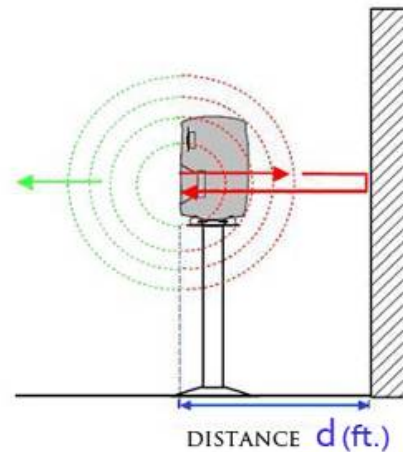

However, since we know the user is attaching them to a boundary, we then can factor the natural woofer phase accumulation in this problematic region as an integral part of the low pass filter of the 10" and high pass filter of the 7". Customarily a second-order high pass and low pass filter electrical filter (crossover) are 180 degrees out of phase at the center frequency.

As a result, manufactures usually just flip the polarity on the high pass side to smooth the summation (often neglecting polar tilt and the time domain). In our wall mounted case, however, the wall dip is introducing additional poles to each side of the center frequency. The side benefit is the 7" driver polarity no longer needs to be flipped. The acoustic summation now has an in-phase characteristic similar to an even-order Linkwitz-Riley network.

---

## Developing a Reference Class On-Wall

In summary, the natural dip in frequency response that wall mounted speakers suffer is the result of phase difference between the direct radiation and the boundary reflection at the listener. Legacy employs the additional filter poles created by this acoustic phenomenon within the crossover strategy to advantage, thereby greatly reducing the dip while reducing the electrical losses of conventional filter poles.

As always, we pair match when tuning and verify all product performance when it leaves the factory.

See the frequency response attached on the next page.

Please note how consistent the Silhouettes are with each other.

# Developing a Reference Class On-Wall

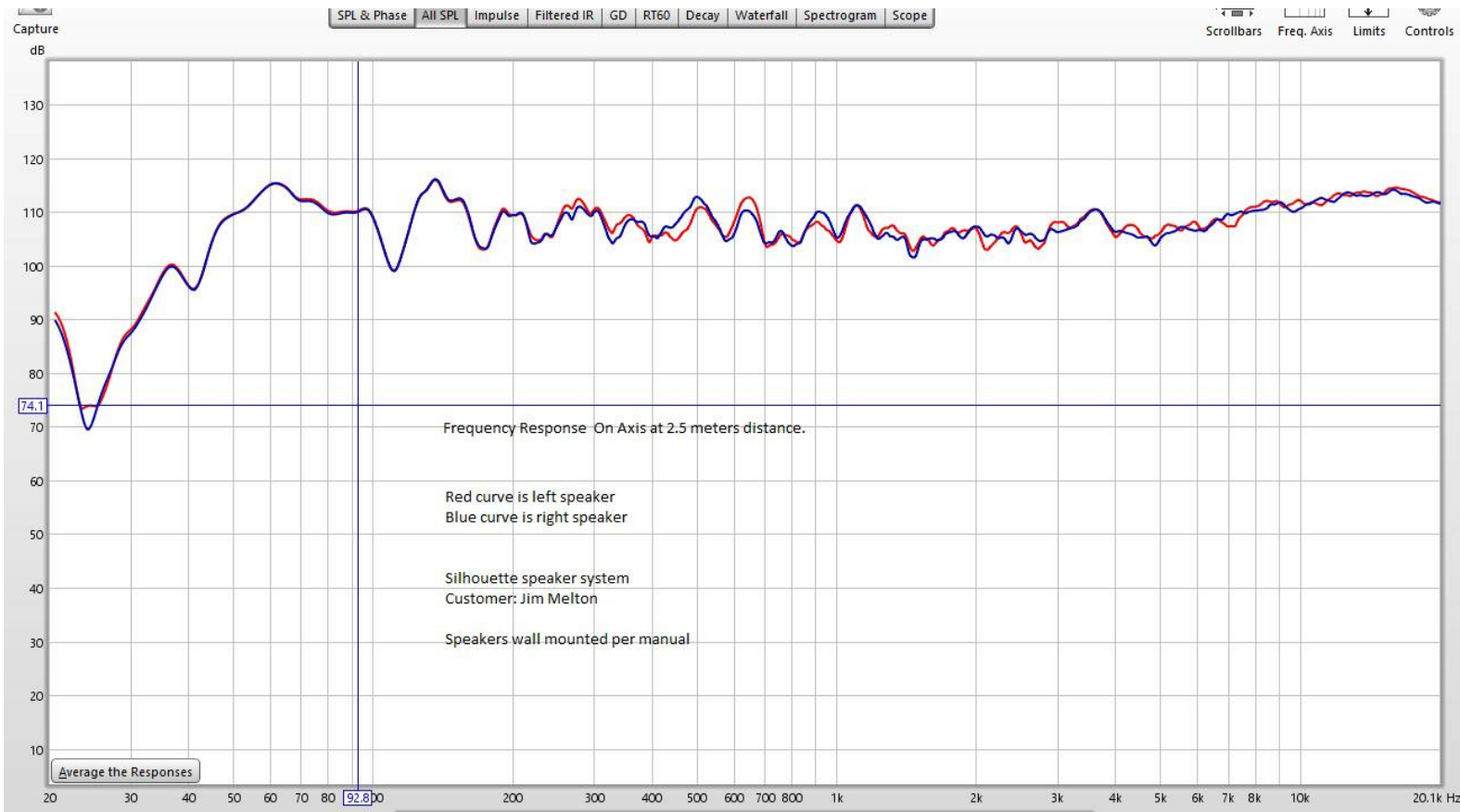

On a personal level I have been curiously surprised by the depth of image and precision the Silhouette provides. I honestly did not realize that an on-wall could be this convincing spatially. Hmm. Learn something new every day.

-Bill Dudleston  
President, Chief Engineer

# Specifications

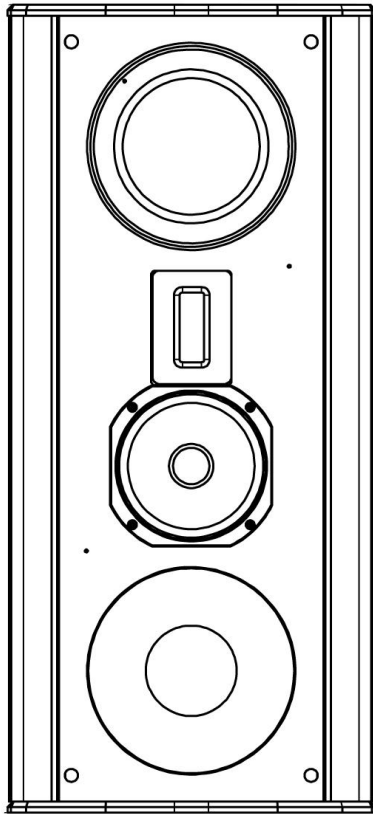

<b>Application:</b>	<b>Low profile articulate full range main or side on-wall</b>
<b>System Type:</b>	<b>4 driver, 3 way passive radiator</b>
<b>Tweeter:</b>	<b>4" AMT folded ribbon</b>
<b>Midwoofer:</b>	<b>7" silver/graphite woven diaphragm, cast frame, phase compensation plug</b>
<b>Bass:</b>	<b>10" low profile custom motor, cast frame</b>
<b>Passive Radiator:</b>	<b>10" mass loaded</b>
<b>Low Freq. Alignment:</b>	<b>Assisted B6</b>
<b>Inputs:</b>	<b>1 pair binding post, recessed cup</b>
<b>Mounting:</b>	<b>Wall mount bracket included</b>
<b>Freq. Response:</b>	<b>42Hz-28kHz</b>
<b>Impedance:</b>	<b>4 Ohm</b>
<b>Sensitivity:</b>	<b>92 dB (2.83V @ 1m)</b>
<b>Crossover:</b>	<b>250, 2.5k</b>
<b>Cabinet Size/Weight:</b>	<b>36.5" x 16.5" x 5.125" , 54 lbs each</b>

---

## CE Declaration of Conformity

Legacy Audio

3023 E. Sangamon Ave.  
Springfield, IL 62702 USA  
800-283-4644

States that this product is in conformity with the with the essential requirements and other relevant provisions of:

Low Voltage Directive 2006/95/EC  
EMC Directive 2004/108/EC



All information contained in this manual is accurate to the best of our knowledge at the time of publication. In keeping with our policy of ongoing product improvement, we reserve the right to make changes to the design and features of our products without prior notice.

## WEEE Compliance

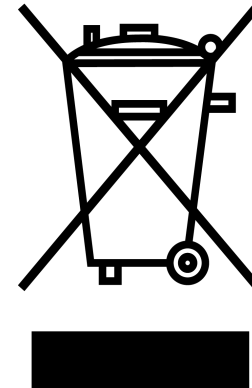

Product Disposal -  
Certain international, national and/or local laws and/or regulations may apply regarding the disposal of this product. For further detailed information, please contact the retailer where you purchased this product or the Legacy Audio Distributor in your country. A listing of Legacy Audio Distributors can be found on the Legacy Audio website [www.legacyaudio.com](http://www.legacyaudio.com) or by contacting Legacy Audio at: 3023 E. Sangamon Ave., Springfield, IL 62702, USA—Phone: +1 217 544-3178.

Notes:



©2017 Legacy Audio  
3023 E Sangamon Ave.  
Springfield, IL 62702  
Phone: 800-283-4644  
Fax: 217-544-1483