

PATHOS

# AURIUM

HEADPHONES CLASS A TUBE AMPLIFIER

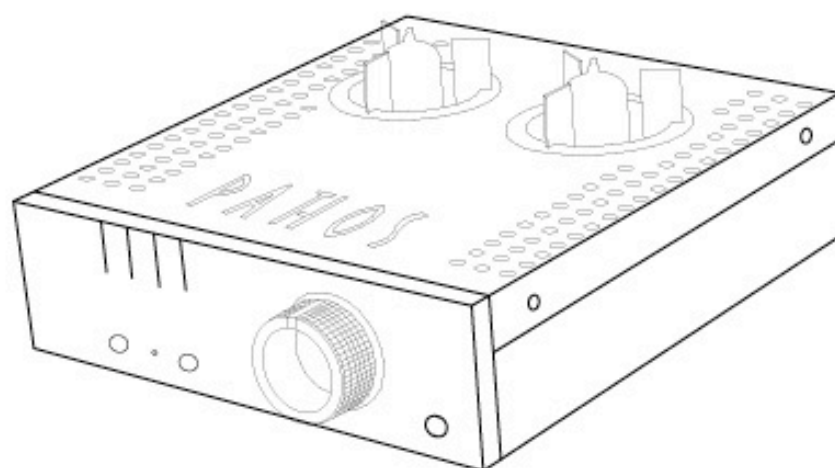

## OPERATING INSTRUCTIONS

Before operating the unit, please read this manual thoroughly, and retain it for future reference.

**Important notice:** This English manual is the official release of the operating instructions for the Pathos Aurium.

Versions in other languages may be provided by local Pathos authorized distributors, and must comply with this version in all parts.

# Congratulations

Congratulations on your purchase of the Pathos AURIUM

Audiophile-quality headphones, something that we all thought belonged to the '70s, are back. Music enthusiasts from all around the world are upgrading their listening experience by getting rid of earbuds and connecting high-end headgear to their portable digital players.

With such great stuff on hand, a shame the only available holes are MP3 players' ones, as most quality amps have lost their jack sockets since decades. Pathos designers faced this new challenge: can we squeeze our very best quality and technology into a few cubic centimeters?

The result is the newest Aurium headphone amp.

Pure class A, tube pre stage and MOS-FET power stage, zero feedback, the Aurium performs what audiophiles are used to from Pathos: exquisite musicality, transparency, dynamics and total lack of listening fatigue. Flexibility is granted by the possibility to adjust output impedance from 16 to 1,000 Ohm, in order to provide a perfect interface with any kind of headphone.

The volume control — a critical component in every amp — is operated by means of a high precision Burr-Brown device.

## **Don't skip the BS\*, please**

Sure, you know how to connect and operate an amplifier.

You are clearly an audio expert or you won't have this manual in your hands!

Nevertheless, there are precautions and safety instructions that you should be aware of.

Before connecting, operating or adjusting this product, please read the instruction booklet carefully and completely. Retain it for future reference.

\* Boring Stuff

Serial number is indicated on the box and on the rear panel. Record the serial number in the space provided below. Refer it whenever you call upon your Pathos dealer regarding this product.

SERIAL No. \_\_\_\_\_

## Important Safety Instructions

Any changes or modifications not expressly approved in this manual voids the warranty and your authority to operate this equipment.

Always disconnect the unit from the AC outlet before connecting or disconnecting any cables

Service should only be performed by authorized Pathos personnel. Users are not allowed to perform any service to this appliance.

Do not modify safety device and do not remove ground of power plug.

Make sure that power cord is protected from being bent, or stepped, especially close to the wall plug and on the rear panel inlet.

AC extension cords are not recommended for use with this product.

Do not place the unit in a confined space, such as a bookcase or built-in cabinet. Do not place the unit on a rug or other soft surface. Always make sure the ventilation of the apparatus is not covered at any time.

Do not expose the unit to rain, moisture, extremely high or low temperatures.

Also avoid locations subject to vibration and excessive dust.

Avoid placing it in direct sunlight or close to a source of heat.

Do not place bottles, vases, or other objects containing liquids, open flame sources such as lighted candles on the unit.

Should any solid object or liquid fall into the cabinet, unplug the unit and have it checked by qualified personnel before operating it any further.

Always keep any electrical equipment out of the reach of children.

Always unplug this unit during lightning storms or when unused for long periods of time.

The unit retains AC power as long as is connected to the wall outlet, even when the unit is turned off.



Do not throw away the battery with general house waste, dispose of it correctly as chemical waste. Marking by "CE" symbol indicates compliance of this device with the EMC (Electromagnetic Compatibility) and LVD (Low Voltage Directive) standards of the European Community.

## Limited Warranty

The reference for the guarantee is always national distributor where the machine was sold for the first time.

Pathos warrants this product to be free from defects in materials and workmanship (subject to the terms set forth below). Pathos will repair or replace (at Pathos's option) this product or any defective parts in this product. Warranty periods may vary from country to country. If in doubt consult your dealer and ensure that you retain proof of purchase. To obtain warranty service, please contact the Pathos authorized dealer from which you purchased this product. If your dealer is not equipped to perform the repair of your Pathos product, it can be returned by your dealer to Pathos or an authorized Pathos service agent. You will need to ship this product in either its original packaging or packaging affording an equal degree of protection.

This warranty is void if:

- the factory-applied serial number has been altered or removed from this product; or
- this product was not purchased from a Pathos authorized dealer.

You may call Pathos or your local Pathos distributor to confirm that you have an unaltered serial number and/or you made a purchase from Pathos authorized dealer.

This warranty does not cover cosmetics damage or damage due to acts of God, accident, misuse, abuse, negligence, commercial use, or modification of, or to any part of, product.

This warranty does not cover damage due to improper operation, maintenance or installation, or attempted repair by anyone other than Pathos or Pathos dealer, or authorized service agent which is authorized to do Pathos work.

Any unauthorized repairs will void this warranty.

This warranty does not cover products sold AS IS or WITH ALL FAULTS.

REPAIR OR REPLACEMENTS AS PROVIDED UNDER THIS WARRANTY ARE THE EXCLUSIVE REMEDY OF THE CONSUMER. PATHOS SHALL NOT BE LIABLE FOR ANY INCIDENTAL OR CONSEQUENTIAL DAMAGES FOR BREACH OF ANY EXPRESS OR IMPLIED WARRANTY IN THIS PRODUCT. EXCEPT TO THE EXTENT PROHIBITED BY LAW, THIS WARRANTY EXCLUSIVE AND IN LIEU OF ALL OTHER EXPRESS AND IMPLIED WARRANTIES WHATSOEVER INCLUDING, BUT NOT LIMITED TO, THE WARRANTY OF MERCHANTABILITY AND FITNESS FOR A PARTICULAR PURPOSE.

Some countries and US states do not allow the exclusion or limitation of incidental or consequential damages or implied warranties so the above exclusions may have other statutory rights, which vary from state to state or country to country.

For any service, in or out of warranty, please contact your dealer.

## About your unit

### Content

Package includes following articles:

Aurium, power supply, power cord, user manual.

In case any of the above items is not included, please contact shop or authorized Pathos dealer.

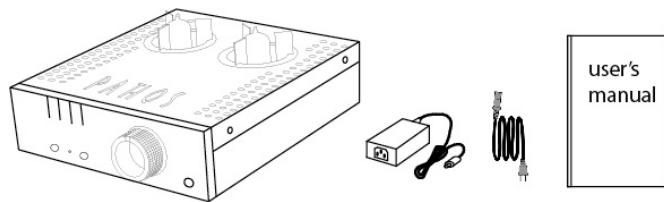

### Packaging

When unpacking your Aurium, always handle it with care. Store all packaging materials in a dry place for future shipments. In case of transport or shipment, the original packaging will properly prevent transit damages.

### Placement

Choose the installation location carefully.

Aurium should generally be placed close to your amplifier, thus keeping interconnecting cables short.

Do not place in a sealed area such as a bookcase or in a cabinet. Do not place the unit on an unstable surface or shelf. The unit may fall, causing serious injury to a child or adults as well as serious damage to the product.

### Heat buildup

Do not place anything on top of the cabinet that might block the ventilation holes and cause malfunctions. Your Aurium heats up during operation, this is not a malfunction. A suggested distance of at least 10cm on each side and 10cm from the top will ensure a sufficient air flow to cool down the unit.

### Vacuum Tubes

Your Aurium is provided with a pair of ECC88 / 6922 tubes. In case you need to replace vacuum tubes, always use same type.

In quality of manufacturer, Pathos choose the brands according to their sound quality performance and availability.

In the market you may find many others brands that can replace pretty well the supplied tubes; NOS, for military use, with gold pins and so on may improve sonic quality of the amplifier as long as they are equivalent to the ECC88.

**NOTE:** is not recommended to leave your Aurium switched on 24 hours a day. This habit for some audiophiles does not induce benefits in Aurium's musical performances and will shorten tubes' life.

### Warm-up

For superior sonic performances, a warm-up period of approximately twenty minutes is recommended before the Aurium is used.

### Cleaning

Before cleaning, be sure to turn off and unplug the unit.

Clean the cabinet, panel, and controls with a soft cloth slightly moistened with clean water. Do not use any type of detergent, abrasive pad, scouring powder, thinner, or solvent such as alcohol or benzene.

### Service

In the unlikely event your Aurium should require service, always refer to your Authorized Pathos Dealer or to the Authorized Pathos Distributor of your country.

### Before you get started

Turn off the power to all components before making any connections.

Do not connect the AC power cord until all of the connections are completed.

Be sure to make firm connections.

## Dimensions

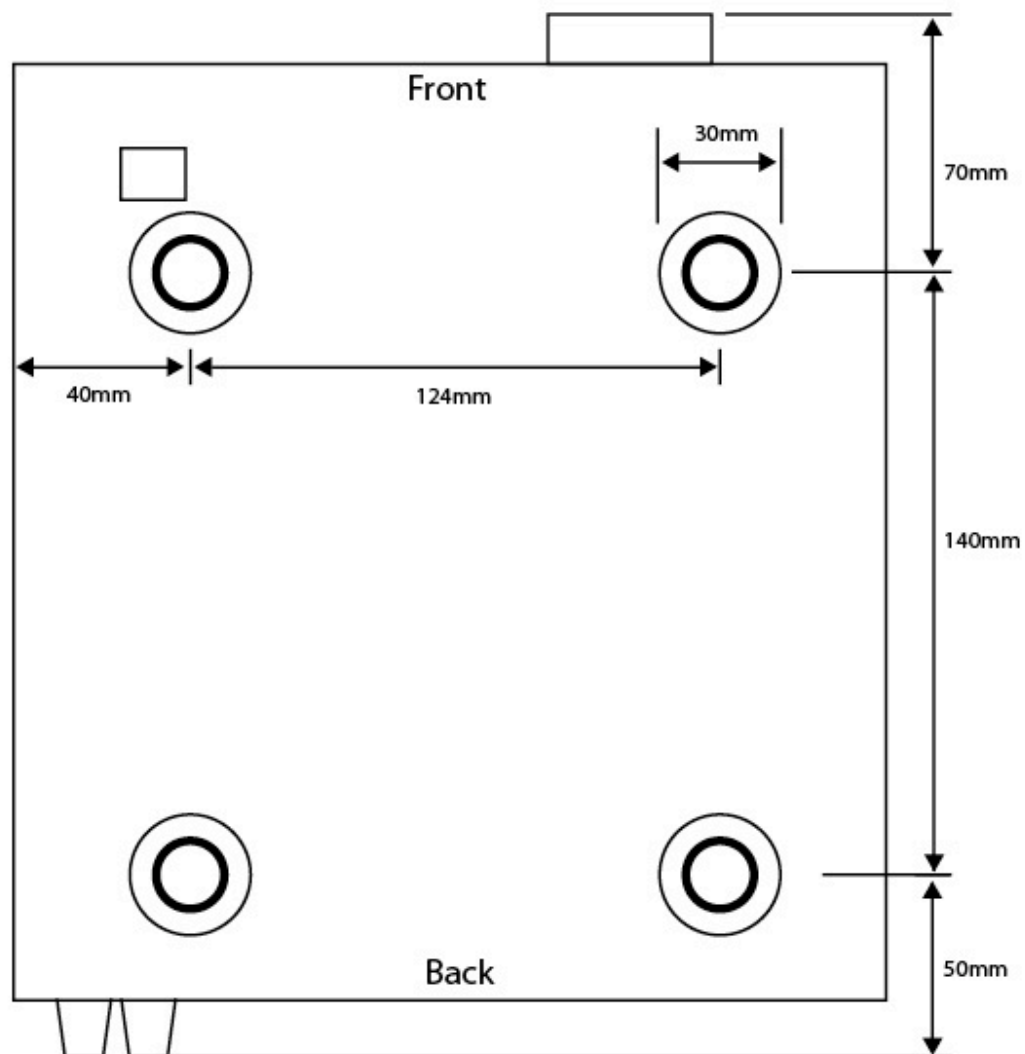
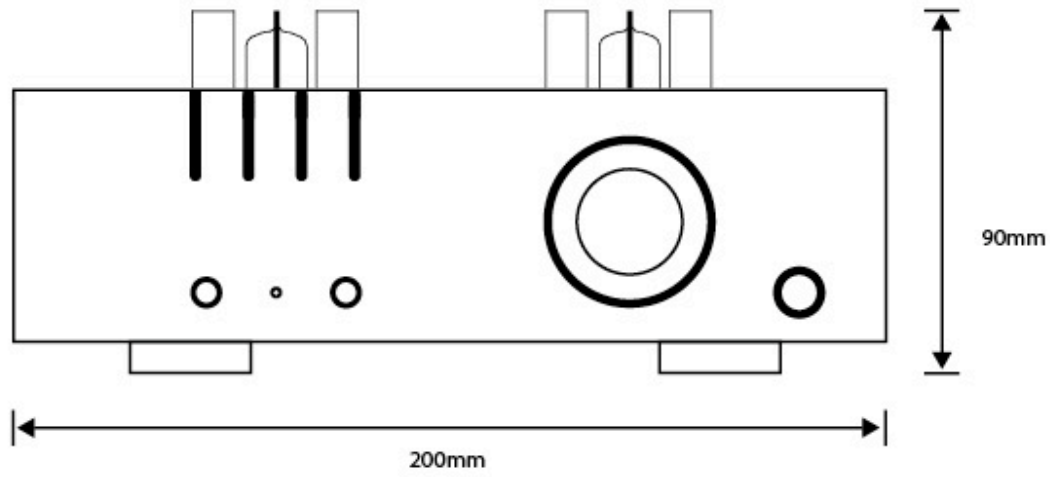

# Connections & Controls

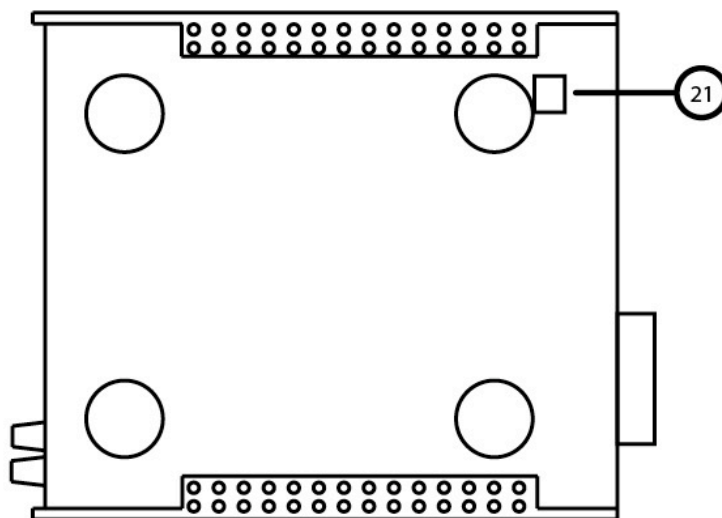
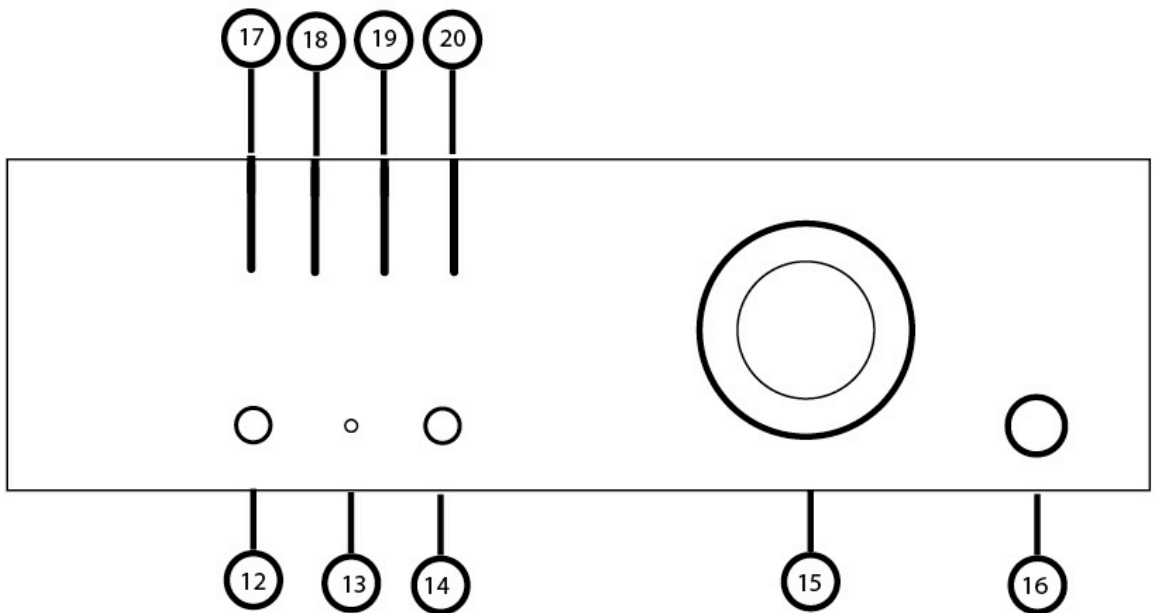
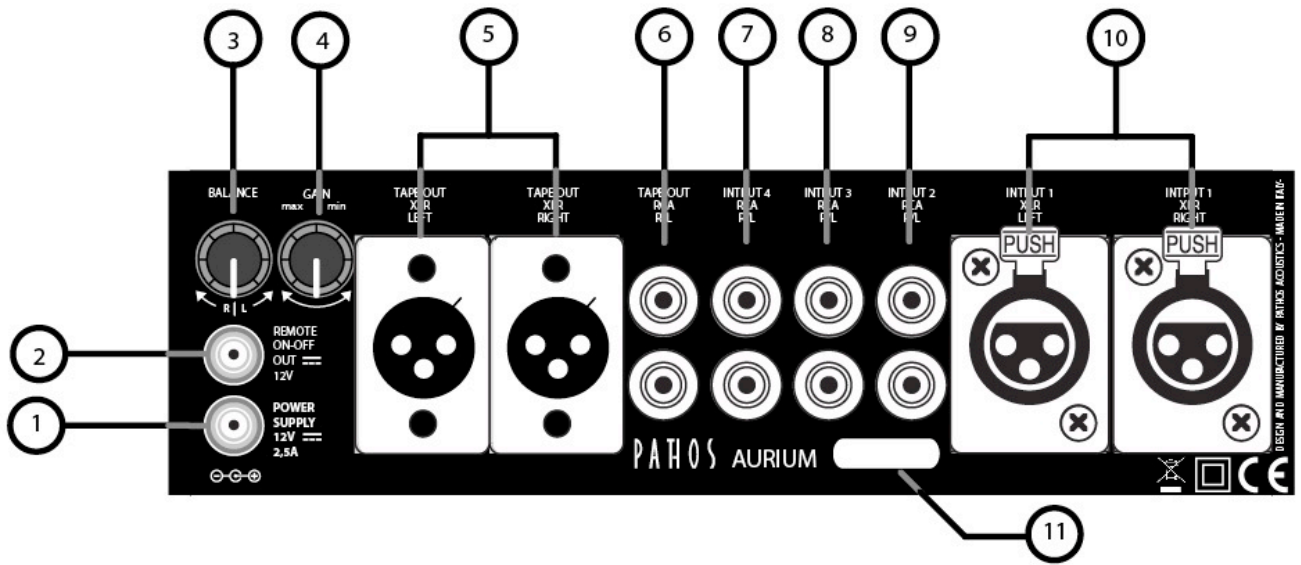

## CAUTION:

When connecting your Aurium to other components, make sure all units are off.

**NOTE:** Pathos Acoustics recommends to use only high quality interconnecting cables. Not using appropriate cables prevents your amplifier, your sources, and your loudspeakers from delivering their full potential. The wiring to and from the amplifier should be arranged in a neat way. It is advisable to separate AC cords from signal and speakers cables, to avoid hums and noise from being introduced into your system.

## Serial number.

Serial number is indicated on the box and on the rear panel (11). Refer it whenever you call upon your Pathos dealer regarding this product.

## Power Supply & Swith ON.

Connect the power supply output (B) into the socket on the rear panel of the unit (1).

Connect the power plug of the power supply input (A) to the power cord that came with the box and plug the cable into the socket on the wall.

When Aurium is properly powered the power LED (13) will turn red, indicating that Aurium is on standby mode (standby consumption is less than 1W).

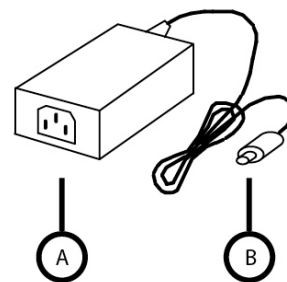

Picture 3

In addition to the Power LED will light the LED on the input selector input referred 1 (17).

In standby mode, the input selector is always working to ensure the functioning of the TAPE OUOT.

To turn on simply press the power button (12) on the front panel, the power LED (13) goes from red to green and starts flashing after about 10 seconds and remain on.

From now Aurium is on and ready to work.

To turn off just hold down the power button (12) for 2 seconds and the power LED (13) goes from green to red.

Aurium is in standby mode.

## Inputs

Aurium has 4 inputs, 1 balanced XLR and 3 unbalanced RCA.

To select the desired input just press the input selector button (14) on the front panel, for each input corresponds to a LED on the front panel.

Input 1: Balanced XLR (10) corresponds to the LED (17)

Input 2: Unbalanced RCA (9) corresponds to the light (18)

Input 3: Unbalanced RCA (8) corresponds to the light (19)

Input 4: Unbalanced RCA (7) corresponds to the light (20)



## Tape Out

Aurium has two outputs "bypass" calls TAPE OUT, a Balanced XLR (5) and an unbalanced RCA (6) that replicate the same signal from the input selected.

Even when Aurium is in standby mode, you can select the input.

connecting the "OUT TAPE" to the input of a remote audio amplifier: when selecting a source in the Aurium, the signal is then by-passed to the plug TAPE OUT and it is as if it was connected directly to the sources, even if Aurium is turned off

In this way facilitate the connections without having to rewire the system and being able to use high quality connections. If you want to listen to your domestic set just switch off on standby Aurium and select the desired source through Aurium, if you want to listen with headphones you can turn off the main amplifier and turn Aurium on.

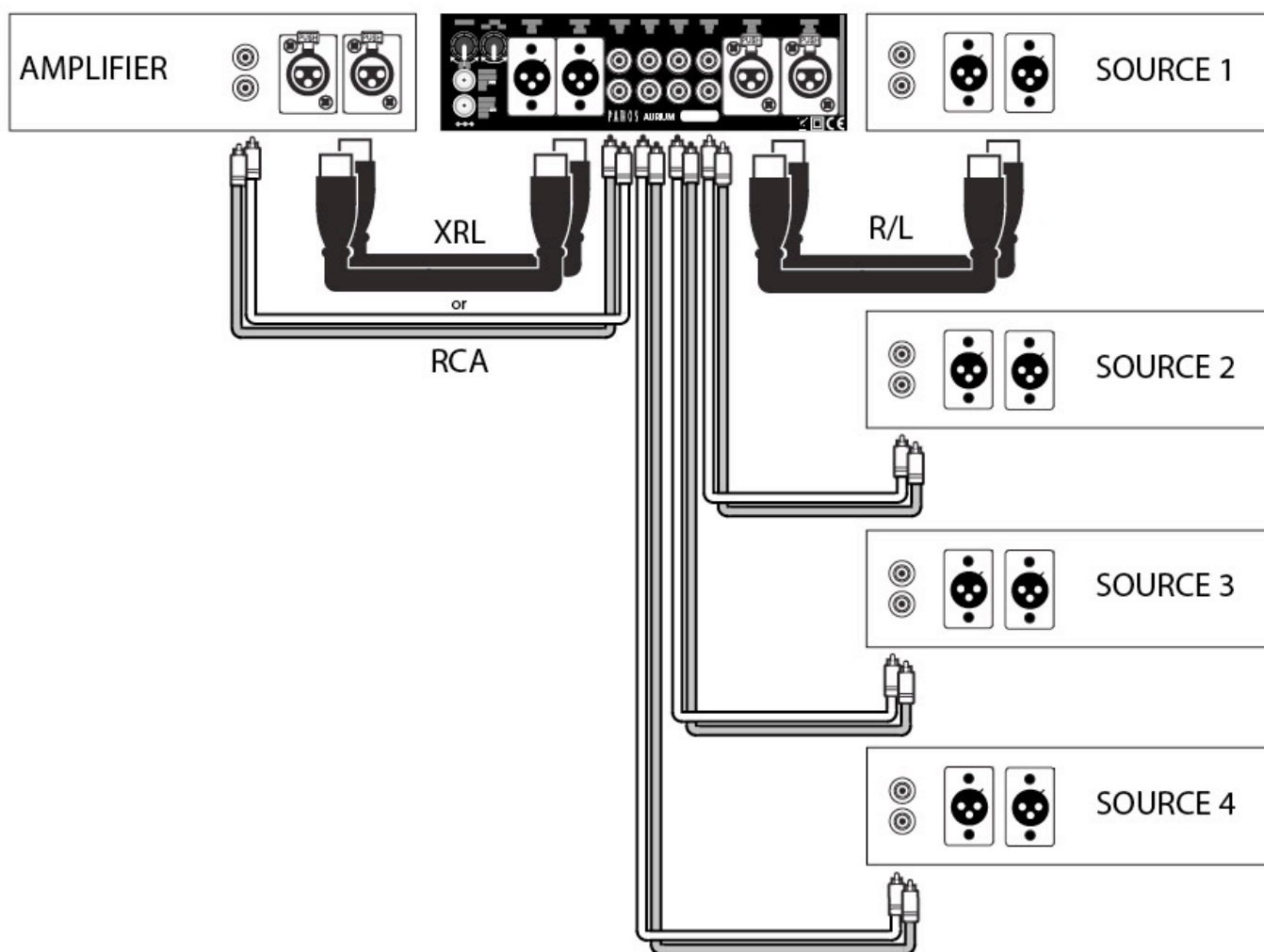



## Headphone

On the front panel (16), you can connect a headset with a 6.3 mm jack connection. The headphone amplifier is equipped with three sound adjustment: Volume, Gain and Balance.

### Volume:

using the knob on the front panel (15) you can adjust the volume from the minimum (mute) to the maximum.

The adjustment is made through the 270 ° rotation of the knob.

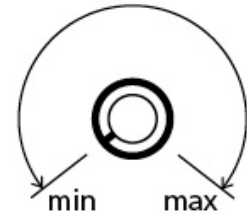

### Gain:

using the knob on the rear panel (4) you can select the output gain in the headset. Given the large difference in impedance and sensitivity of the headphones on the market (from 16 to 1000 ohms) you need to adjust the gain to decrease if you use a low-impedance headphones, or increase it if you use a headset at high impedance.

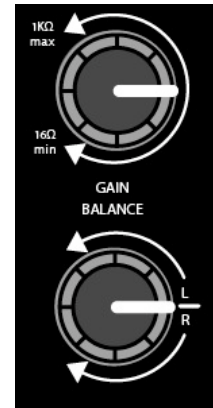

For the correct adjustment Volume / Gain Pathos recommend the following procedure:

- Lower the gain to a minimum before connecting a headset
- Set the master volume at half scale
- Increase the gain in order to perceive a good listening volume.

By doing so you will have the perfect flexibility of using the volume knob on the front panel, preventing excessive volume

### Balance:

using the knob on the rear panel (3) it is possible to balance the output left / right to adapt to all possible needs.

## Remote ON/OFF

Aurium is provided with one connector for switching on/off via remote (2).

Remote ON/OFF OUT: when unit is on, 12VDC are on the connector to turn on other machines provided with compatible remote.

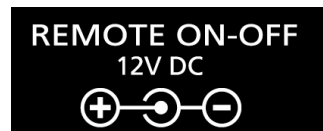

## Attenuators

On the bottom side of the amplifier, there is a component composed of 4 micro switches (21) that manages the attenuation of each input.

With these it is possible to activate a system of attenuation of 6dB within dell'aurium to allow use of sources with high output.

Moving the lever to the "ON" to activate the front attenuation.

Respectively to the micro switch 1 corresponds to input 1, and so on.

The TAPE OUT output is not affected by this attenuation.

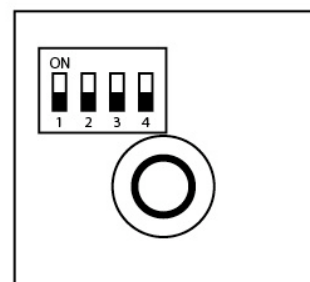

## Technical specification:

Aurium is a tube amp specifically designed for headphones. It works in pure class A zero-feedback. It consists of:

- an INPUT stage with TAPE OUT to bypass the volume control
- one pre-amp tube in a "differential configuration"
- a volume adjusting stage and a digital controller.
- an output stage "white cathode follower" made by MOSFET (unity gain).
- a self bias circuit which maintains a constant working point of the MOSFET.

The volume controls is provided with an high class ALPS potentiometers. Such potentiometer, however, doesn't manage "directly" the audio signal but it controls the digital stage of the volume control. In other words the audio signal doesn't pass through that potentiometer.

In order to meet any kind of sources with different output levels, the machine is provided with a micro-switch for each input so that you can change the sensitivity to avoid signal saturation.

To protect the headphone, it has been implemented an "unorthodox" solution which uses an electronic intelligent circuit rather than the typical RC-network which generally reduces the damping factor.

The balanced XLR output tape has been desired by Pathos to enjoy and fully appreciate the high quality of the Aurium. In fact, by using a balance sources, the sound quality will be excellent and the Aurium and other amplifier connected to this output, will able to give the best performances.

Output Power: 3,6W @ 32 Ohm

Output impedance: 0,5 Ohm

Max output level: 7V RMS max

Frequency response: 10Hz – 80KHz

THD: < 0,1%

Analogue inputs: 1 stereo balanced XLR & 3 stereo unbalanced RCA line

Analogue outputs: 1 stereo balanced XLR & 1 stereo unbalanced RCA line (bypass from source)

Max input level: 3,2 V RMS unbalance  
1,6+1,6 V RMS balance  
6,4 V RMS unbalance (con attenuatore)  
3,2+3,2 V RMS balance (con attenuatore)

Main voltage: 90-250 V 50/60Hz

Power consumption: 30W

Size: 260 x 200 x 90 mm

Weight: 3Kg



# PATHOS

Pathos Acoustics srl  
Via Palù 50/52  
36040 Grumolo delle Abbadesse  
Vicenza  
ITALIA  
[www.pathosacoustics.com](http://www.pathosacoustics.com)