

dCS Vivaldi Upsampler
Digital to Digital Converter

User Manual
Software Release 2.0x
November 2016

© Data Conversion Systems Ltd. 2012 - 2016

Price UK £10.00

All rights reserved. No part of this publication may be reproduced, stored in or introduced into a retrieval system, or transmitted in any form, or by any means (electronic, mechanical, photocopying, recording or otherwise) without the prior written permission of *dCS*¹. Any person who does any unauthorised act in relation to this publication may be liable to criminal prosecution and civil claims for damages.

Information contained in this manual is subject to change without notice, and whilst it is checked for accuracy, no liabilities can be accepted for errors.

¹ *dCS* is Data Conversion Systems Ltd. Company registered in England No. 2072115.

Contents

Using the dCS Vivaldi Upsampler for the first time	5
What's in the box?	5
Positioning the unit	5
Important Safety Instructions	6
Safety Notice	7
Made for iPod® and iPhone®	8
Step-by-Step Guide	9
Preliminaries	9
STEP 1 – Connecting a PCM input	10
Connecting to a Single AES or SPDIF source	10
Connecting to an SDIF-2 PCM Source	10
STEP 2 – Connecting an Output	11
Dual AES	11
Single wire PCM	12
STEP 3 - Setting the Sync Mode	13
Using a Master Clock	13
Using the Vivaldi Clock's enhanced clocking system	13
A full Vivaldi system	14
STEP 4 – Using the USB1 interface with a computer	15
Compatibility	15
Setting the USB Audio Class	15
Loading the Windows driver for USB Class 2	15
Basic setup with a PC	16
A word about Music Playing Software	17
Selecting the Vivaldi Upsampler as your Audio Output device	17
STEP 5 – UPnP Network Connection	18
Compatibility	18
Basic set-up	18
Playing music with AirPlay	25
Using the Vivaldi Upsampler with Spotify Connect	25
Using the Vivaldi Upsampler with Tidal	25
Using the Vivaldi Upsampler with Roon	25
STEP 6 - Using the Vivaldi 2.0 app as a remote control	26
STEP 7 – Using the USB2 input	28
STEP 8 – Setting the Sync Mode for Computer Audio sources	29
Using the DAC in Universal Master Mode	29
Using the DAC and Upsampler with a Master Clock	30
Advanced options	31
Using the Web Client interface	31
Customising the input configuration	32
Front Panel	33
Remote Control Receiver	33
Display	33
Power Button	34
Menu Button	34
Filter Button	34
Input Button	35
Output Button	35
Rear Panel	36
Digital Outputs	36
Digital Inputs	36
Word Clock Input / Output	37
Network Interface	37
USB Interfaces	38
Test interface	38
Mains inlet	38
Label	38

The Menu	39
Using the Menu	40
INFORMATION Menu	41
Unit Status	41
Version	41
Contact	41
Update	41
UPSAMPLER SETTINGS Menu	42
Sync Mode	42
Dual AES	42
Clone Mode	43
USB Class	43
DSD Pass-Through	43
DXD Mode	44
EasyPlay	44
RS232 Mode	44
CONFIGURATION Menu	45
Settings Lock	45
Save Configuration	45
Restore Configuration	45
Reset Input Names	45
Factory Reset	45
DISPLAY SETTINGS Menu	46
Brightness	46
Display On/Off	46
GENERATOR Menu	46
Channel Check	46
Phase Check	46
Burn In	46
Specification	47
Maintenance and Support.....	49
Service and Maintenance	49
Replacing a Blown Mains Fuse	49
Cleaning the case	49
Limited Warranty	50
If you need more help	51
Software History	52

USING THE *dCS* VIVALDI UPSAMPLER FOR THE FIRST TIME

Congratulations on purchasing your *dCS* Vivaldi Upsampler.

Before using your unit, please read this section and the Step by Step Guide. This will enable you to set the unit up quickly and safely with your hi-fi system.

From time to time, *dCS* will release updated software on CD-R that you can install yourself using the **Update** feature. Please check our web-site occasionally to see if new Vivaldi Upsampler software is available, or consult your dealer.

What's in the box?

Check that the box contains the following items:

- *dCS* Vivaldi Upsampler
- Manual and Menu / Setup Guide
- Power cable
- 2 AES cables
- USB-A to USB-B cable
- Ethernet cable
- BNC cable
- 3-way RS232 cable
- Spare fuses
- Spotify flyer

Notify your dealer as soon as possible if anything is missing or damaged. We suggest that you retain the original packaging for possible future use. If this is not possible, replacement packaging can be ordered from *dCS* or our distributors. Details can be found on our web site at www.dcsLtd.co.uk.

A *dCS* Premium remote control is supplied with the **Vivaldi DAC**, it is available as an optional extra.

Positioning the unit

For best sound quality, the units in the Vivaldi range are designed to be mounted on separate shelves of a rack, although they may be stacked directly on top of each other if this is absolutely necessary. Place each unit on a firm, vibration free base, allowing convenient connection to the other parts of your system. To prevent overheating, we recommend that you leave some free space around the unit to allow for ventilation.

The unit is supplied with 4 feet fitted. If you prefer a 3-feet layout, unscrew the two back feet, remove the two black cores using a 2.5mm A/F Allen key, fit one of the cores in the middle position and replace the foot. Take care not to cross-thread the foot!

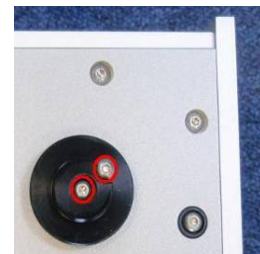
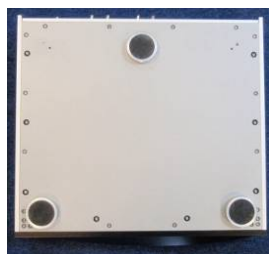
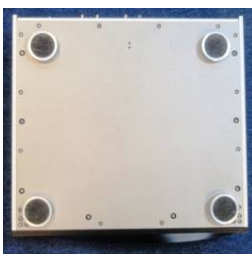

With all feet screwed fully home, the unit will sit level on a flat surface. If you need to do any levelling, you can unscrew any of the feet up to 3 complete turns, to give up to 3mm (1/8") of height adjustment.

Important Safety Instructions

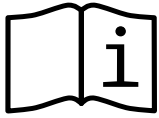

The following statements are required to comply with U.S. safety standard UL60065.

- Read these instructions.
- Keep these instructions.
- Heed all warnings.
- Follow all instructions.
- Do not use this apparatus near water.
- Clean only with dry cloth.
- Install in accordance with the manufacturer's instructions.
- Do not install near any heat sources such as radiators, heat registers, stoves, or other apparatus (including amplifiers) that produce heat.
- Do not defeat the safety purpose of the grounding-type plug. A grounding type plug has two blades and a third grounding prong. The third prong is provided for your safety. If the provided plug does not fit into your outlet, consult an electrician for replacement of the obsolete outlet.
- Protect the power cord from being walked on or pinched particularly at plugs, convenience receptacles, and the point where they exit from the apparatus.
- Only use attachments/accessories specified by the manufacturer.
- Unplug this apparatus during lightning storms or when unused for long periods of time.
- Refer all servicing to qualified service personnel. Servicing is required when the apparatus has been damaged in any way, such as power-supply cord or plug is damaged, liquid has been spilled or objects have fallen into the apparatus, the apparatus has been exposed to rain or moisture, does not operate normally, or has been dropped.

Safety Notice



In the event of the unit developing a fault, please contact your dealer in the first instance.

If you decide to remove safety covers for any reason, disconnect the power cable first. Note that removing covers voids the warranty.

To maintain protection from electric shock, the unit **MUST** be connected to mains earth (ground) via the power cable. Also, unearthed systems do not give the best sonic performance.

Protect the product from dripping or splashing liquids. Liquid-filled objects such as vases must not be placed on the product.



This product is not suitable for operation at altitudes above 2000m.



This product is lead-free and complies with the RoHS directive.

Before connecting the power cable to the unit for the first time, please check that it has been set to the correct operating voltage for your mains supply. The unit's voltage setting is shown on the serial number label. If this does not match your local supply voltage, **DO NOT** attempt to use the unit. Contact your dealer to have the unit reset. Using the unit with the wrong mains setting for your local supply may result in serious damage to the unit and will invalidate the warranty. Do not attempt to reset the voltage yourself.

We do not recommend the use of mains regenerators. However, if you do wish to use a mains regenerator with variable voltage and frequency, we recommend that you set the voltage to match your local voltage and the frequency to either 50Hz or 60Hz **ONLY**.



Damage caused to your Vivaldi Upsampler by misuse of a mains regenerator or by a malfunctioning mains regenerator is not covered by the warranty.



Disposal at end-of-life - the symbol indicates that this product should not be treated as normal household waste. It should be recycled, so please take it to an approved collection facility.

Made for iPod® and iPhone®



“Made for iPod” and “Made for iPhone” mean that an electronic accessory has been designed to connect specifically to iPod or iPhone respectively and has been certified by the developer to meet Apple performance standards. Apple is not responsible for the operation of this device or its compliance with safety and regulatory standards.

iPad®, iPhone, iPod and iPod touch® are trademarks of Apple Inc., registered in the U.S. and other countries.

The Vivaldi Upsampler is compatible with the iPod and iPhone models illustrated below.
Made for:



STEP-BY-STEP GUIDE

This section guides you through setting up the unit for use in various ways.

Preliminaries

The Menu Guide sheet details the menu structure.

For digital interfaces, use with cables designed for digital audio:

- for AES/EBU interfaces use 110Ω screened, twisted pair cables fitted with one male XLR connector and one female XLR connector.
- for SDIF, Word Clock or SPDIF BNC interfaces, use 75Ω coax cables fitted with BNC plugs.



SDIF and Word Clock interfaces require a simple DC-coupled connection. The interfaces may malfunction or not work at all if capacitor coupled cables or cables with built-in networks are used.

- for SPDIF RCA interfaces, use 75Ω coax cables fitted with RCA Phono plugs.
- for TOSLINK optical interfaces, use Toslink fibre-optic cables.
- for the Network interface, use the Ethernet cable provided with the unit.
- for the USB1 interface, use a standard screened USB cable fitted with one type 'A' connector and one type 'B' connector. The internal screen must be connected at both ends.
- Connect the power cable to the power inlet on the Upsampler rear panel, and plug the other end into a convenient power outlet. Set the rocker switch on the rear panel to the **I** position (on).



Please do not use an excessively heavy or inflexible power cable as this may damage the power inlet connector.



The cables supplied with the unit are “commercial grade”, because most owners will have their own “audiophile grade” cables or will prefer to make their own cable choices.

- Press the **Power** button – the unit will display **Vivaldi Upsampler**. Wait about 30 seconds while the Upsampler configures itself.
- If the unit is likely to be set in an unfamiliar state, you can run the **Factory Reset** routine by pressing the buttons in this sequence: **Menu**, **▶**, **▶**, **Menu**, **◀**, **◀**, **Menu**.
- Wait a few seconds while the unit resets itself.

We will start with a basic setup using a standard PCM source.

STEP 1 – Connecting a PCM input

Switch on the source equipment. If appropriate, load a disk / tape and set the machine in PLAY mode to ensure it is generating a digital audio data stream.

Choose one or more of the following sections:

Connecting to a Single AES or SPDIF source

Most digital audio source equipment (such as CD transports, DVD players) is fitted with a single wire digital output, usually on an RCA phono connector.

- Connect your source equipment to the matching input on the Upsampler's rear panel using a suitable cable.
- Press the **Input** button repeatedly until your chosen input is displayed. This will be either **AES**, **SPDIF1 (RCA)**, **SPDIF2 (RCA)**, **SPDIF3 (BNC)** or **Toslink**.

The Upsampler will lock to the source and display **16/44.1 > 96** for example, if the source is a CD player.

Connecting to an SDIF-2 PCM Source



SDIF (**S**ony **D**igital **I**nter**F**ace) is not the same as SPDIF (**S**ony/**P**hilips **D**igital **I**nter**F**ace) and the two are not compatible. Please ensure that you connect to the correct BNC socket.

- Connect the CH1 output on your source equipment to the **CH1** input on the Upsampler's rear panel and the CH2 output to the **CH2** input, using two BNC cables. Connect the word clock output on your source equipment to the **Word Clock In1** or **In2** connector on the Upsampler's rear panel. Ensure the cables are not swapped.
- Press the Upsampler's **Input** button repeatedly until **SDIF** appears on the display.



Set the **Settings > Sync Mode** menu page to **Word Clock 1** or **Word Clock 2** as appropriate.

The Upsampler will lock to the source and display **16/44.1 > 96** for example, if the source is a CD player.

STEP 2 – Connecting an Output

Choose which output interface you want to use and connect it up as described below. The Upsampler's main output is **Dual AES**. You can connect as many outputs as you wish.

Dual AES

Connect the **AES1 Out** and **AES2 Out** ports to matching inputs on your DAC. Use the **Output** button on the front panel to set the output sample rate to 88.2, 96, 176.4, 192, 352.8 or 384kS/s or DSD.



Open the menu, scroll to the **Settings > Dual AES** page and make sure it is set to **On**. (The button sequence is **Menu**, **▶**, **Menu**, **▶**.) If it is not, press the **Menu** button once.

Use the DAC's **Input** button to select the **Dual AES** input. You may need to open the DAC's menu and set it to accept Dual AES.



All dCS DACs are capable of Dual AES operation, older models may be limited to a maximum of 192kS/s. Some other manufacturer's DACs may have 2 single AES inputs that are not Dual AES capable. Please check the DAC manual to be sure.

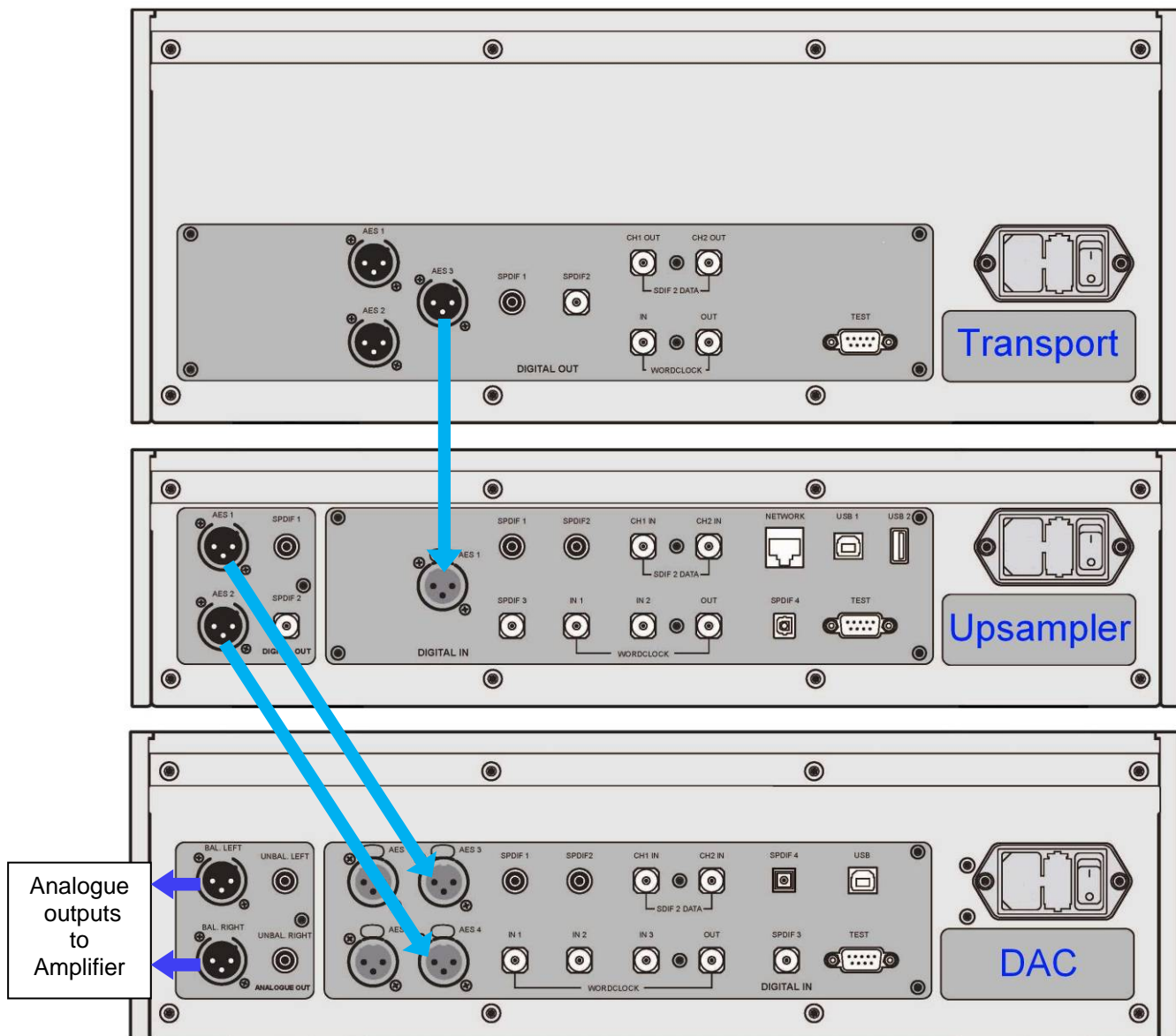

Figure 1 – Connecting the Dual AES output

Single wire PCM

Connect one or more of the PCM outputs (**AES1 Out**, **AES2 Out**, **SPDIF1 Out**, **SPDIF2 Out**) to matching inputs on your DAC. Use the **Output** button on the front panel to set the output sample rate to 32, 44.1, 48, 88.2, 96, 176.4 or 192kS/s or DSD.



If you want to use the **AES1** and **AES2** outputs in single-wire mode, open the menu, scroll to the **Settings > Dual AES** page and make sure it is set to **Off**. (The button sequence is **Menu**, **▶**, **Menu**, **▶**.) If it is not, press the **Menu** button once.

Use the DAC's **Input** button to select that input.



If the output sample rate is **352.8** or **384**, the two SPDIF outputs will be muted.
The Upsampler will not output sample rates that are lower than the input sample rate.

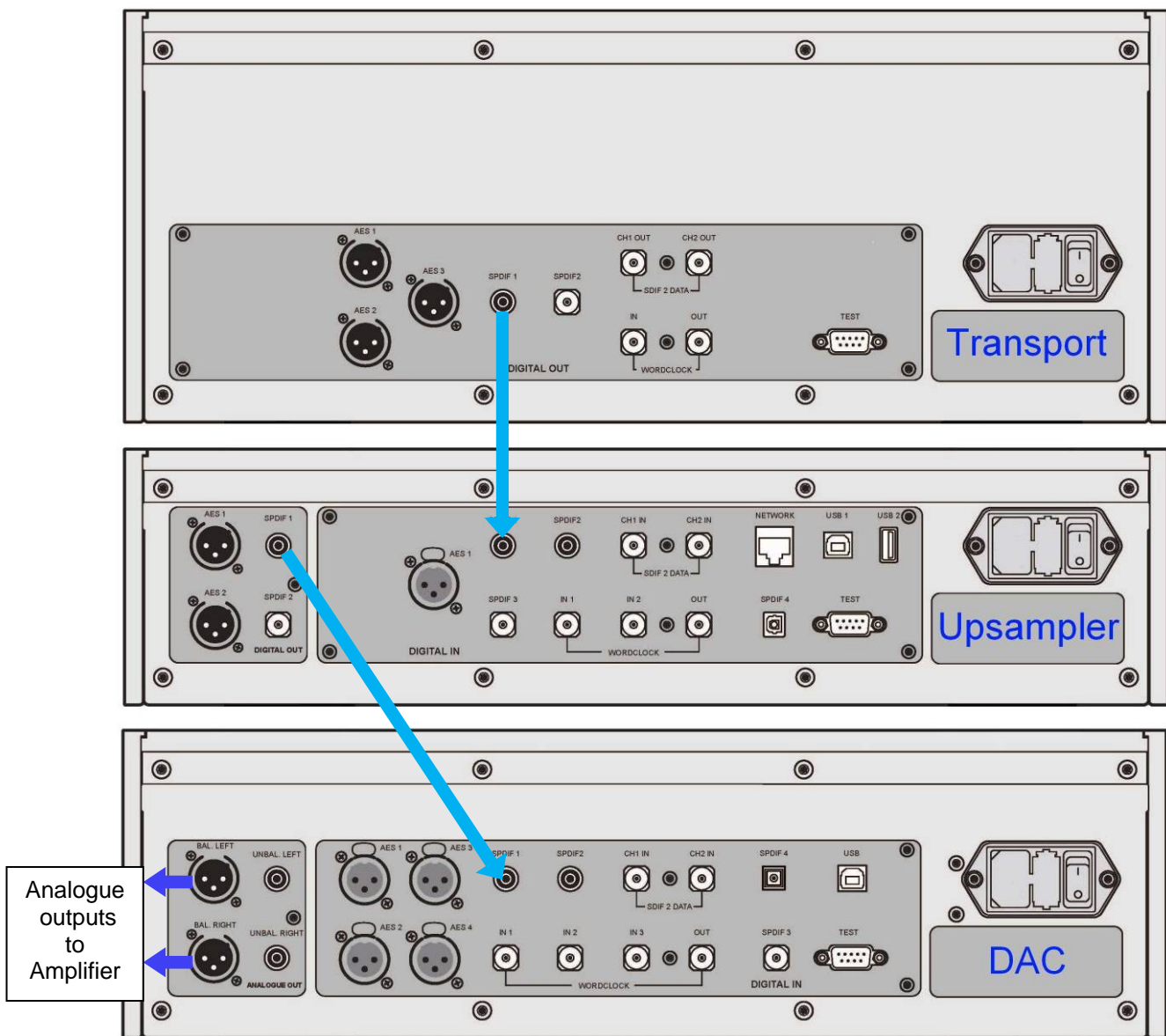

Figure 2 – Connecting a single-wire SPDIF output

Connect the DAC's outputs to the amplifier & speakers. Start the source playing and set the DAC's Volume control to a comfortable level. You should have audio at this point.

STEP 3 - Setting the Sync Mode



If the Upsampler was reset at the start of this procedure and you have selected the **AES** or an **SPDIF** input, you should see the **Sync Mode - Audio** icon. The system has been set up to lock to the clock generated by the source.

This is the simplest arrangement, but it does not give the best sonic performance due to clock jitter. You can improve the performance by adding a Master Clock to your system.

Using a Master Clock

If you have a Vivaldi Clock (or other dedicated Clock) in your system, lock the source, the Upsampler and the DAC to the Clock for the best performance. To do this:

- Connect the one of the Clock's **Group 1 Word Clock Outputs** to the **Word Clock In 1** connector on the source, Upsampler and DAC.
- Set the Clock **Frequency 1** to suit the source and DAC. For a CD Transport as source with the Upsampler set to output **176.4**, **352.8** or **DSD**, a suitable frequency is **44.1kHz**. For a 48kS/s source (such as a DVD player) with the Upsampler set to output **192** or **384**, a suitable frequency is **48kHz**.
- Select the required input on the Upsampler and DAC. This is important because these units store a different **Sync Mode** setting for each input.



To set the Upsampler to lock to the Clock, open the menu, scroll to the **Settings > Sync Mode** page and check it is set to **Word Clock 1**. (The button sequence is **Menu**, **▶**, **Menu**.) If it is not, press the **Menu** button as necessary until the **W1** icon is displayed.

- When the menu has closed, the Upsampler will display the **W1** icon, provided the clock is recognised.



If there is no signal at the **Word Clock In1** connector or it is not recognisable, the Upsampler will sync to audio and display this icon to warn you.

- The Vivaldi Transport will automatically lock to the Clock and display a **W** icon.
- Set the Vivaldi DAC to sync to Word Clock in a similar way to the Upsampler.

Using the Vivaldi Clock's enhanced clocking system

You may have noticed that the Vivaldi Upsampler has 2 Word Clock inputs, and the Vivaldi DAC has 3. **Word Clock In1** and **In2** are intended to be used together for ease of use in situations where the sample rate of the source often changes. Computer audio is an obvious example of this (the files on our server were recorded at 10 different sample rates), another example is cycling through the Upsampler's output rates to find the best sound. *dCS* products have featured clock multiplication for several years, but it is much more difficult to keep the clock free from jitter when you change from 44.1/88.2/176.4 to 48/96/192.

So the Vivaldi Clock's outputs are split into 2 groups, the idea is that one group is set to 44.1kHz (or a multiple) while the other is set to 48kHz (or a multiple). A Word Clock connection from each group connects to **Word Clock In1** and **In2** of both the Upsampler and DAC.



First, select the input you want to lock to the Clock. Then set the **Settings > Sync mode** menu page in each unit to **Auto W1/W2**, and both units will automatically choose the clock that is synchronous with the data.



If you are using the Transport also, don't forget to connect one of the Clock's 44.1kHz outputs to the Transport's **Word Clock Input!**

A full Vivaldi system

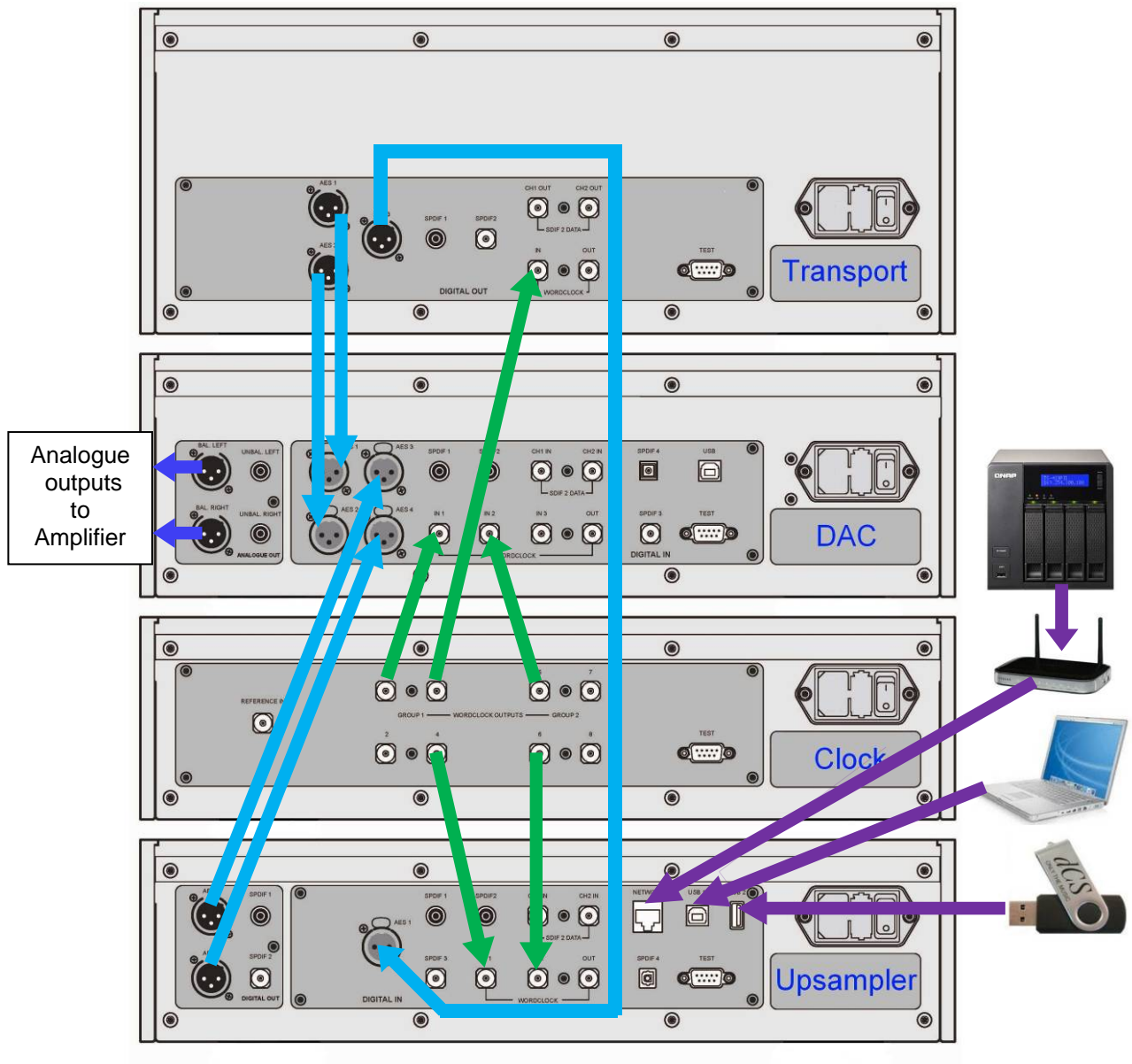

Figure 3 – A 4-box Vivaldi system plus computer audio sources

The following sections detail connection of computer audio sources.

STEP 4 – Using the USB1 interface with a computer

If you do not want to use a computer, you can miss out this step.

Compatibility

The **USB1** interface can be connected to Windows™ 10, Windows™ 8.1, Windows™ 7, Windows™ Vista (SP2 or later), Mac™ OSX (10.5.4 or later) systems or a sound server, running music streaming software.

The interface should work with Linux Ubuntu servers and computers fitted with USB 2.0 interfaces that natively support USB Audio Class 1 or Class 2 operation, but this has not been extensively tested.

Setting the USB Audio Class

There are two USB Audio classes, one of which must be set during system set-up. The Upsampler is shipped set to USB Audio Class 2.

USB Audio Class 1: The interface operates without a special driver at up to 96kS/s.



To select Class 1, open the menu, navigate to the **Settings > USB Class** menu page. The button sequence is: **Menu**, **▶**, **Menu**, **◀**, **◀**, **◀**, **◀**, **◀** and then use the **Menu** button to select the **Class 1** icon.

USB Audio Class 2: The interface operates at up to 384kS/s (including up to DSD/128 as DoP).

For Mac OSX, version 10.6.3 or later is required.

For Windows, the driver files on the dCS USB Class 2 Driver disc supplied must be installed onto the computer before use (see below).



To select Class 2, open the menu, navigate to the **Settings > USB Class** menu page. The button sequence is: **Menu**, **▶**, **Menu**, **◀**, **◀**, **◀**, **◀**, **◀**, and then use the **Menu** button to select the **Class 2** icon.



The Vivaldi Upsampler v2.0x software onwards is not compatible with the 2012-2015 version of the USB Class 2 driver. Please uninstall the old version from your PC and install the 2016 version (which can be downloaded from www.dcsLtd.co.uk).

Loading the Windows driver for USB Class 2

- If ASIO4ALL or any other ASIO driver (e.g. for a sound card) is loaded on your computer, please uninstall it - otherwise the dCS driver will not work correctly.
- Power up the Upsampler and the computer.
- Make sure the Upsampler is set to USB Class 2 - otherwise the driver installation will fail.
- Connect the Upsampler's **USB1** port to the computer's USB port.
- Connect the DAC's **USB** port to the computer's USB port.
- Go to <http://www.dcsLtd.co.uk/products/vivaldi-upsampler/>, click the **Support** link, then click the **Download** button next to **USB Class 2 Driver 2016**.
- Unzip the file to a temporary directory and run the file.
- Follow the on-screen prompts, wait until installation is complete.



If you connect a Vivaldi Upsampler set for USB Audio Class 2 to a Windows computer without first loading the driver, the computer will not be able to find the Upsampler.

Basic setup with a PC

- Connect one of the computer's USB ports to the **USB1** port on the Upsampler's rear panel.
- Press the **Input** button repeatedly until **USB1** is displayed.



Open the Menu and select **Settings > Sync Mode > Master Mode**.

This is the Upsampler's default **Sync Mode** for the USB and Network interfaces. The Upsampler does not lock to the source clock, but uses the Upsampler's internal clock instead. A control signal is sent back to the source to control the delivery of data bursts from the computer. This arrangement avoids the use of the computer's inaccurate and jittery clock.

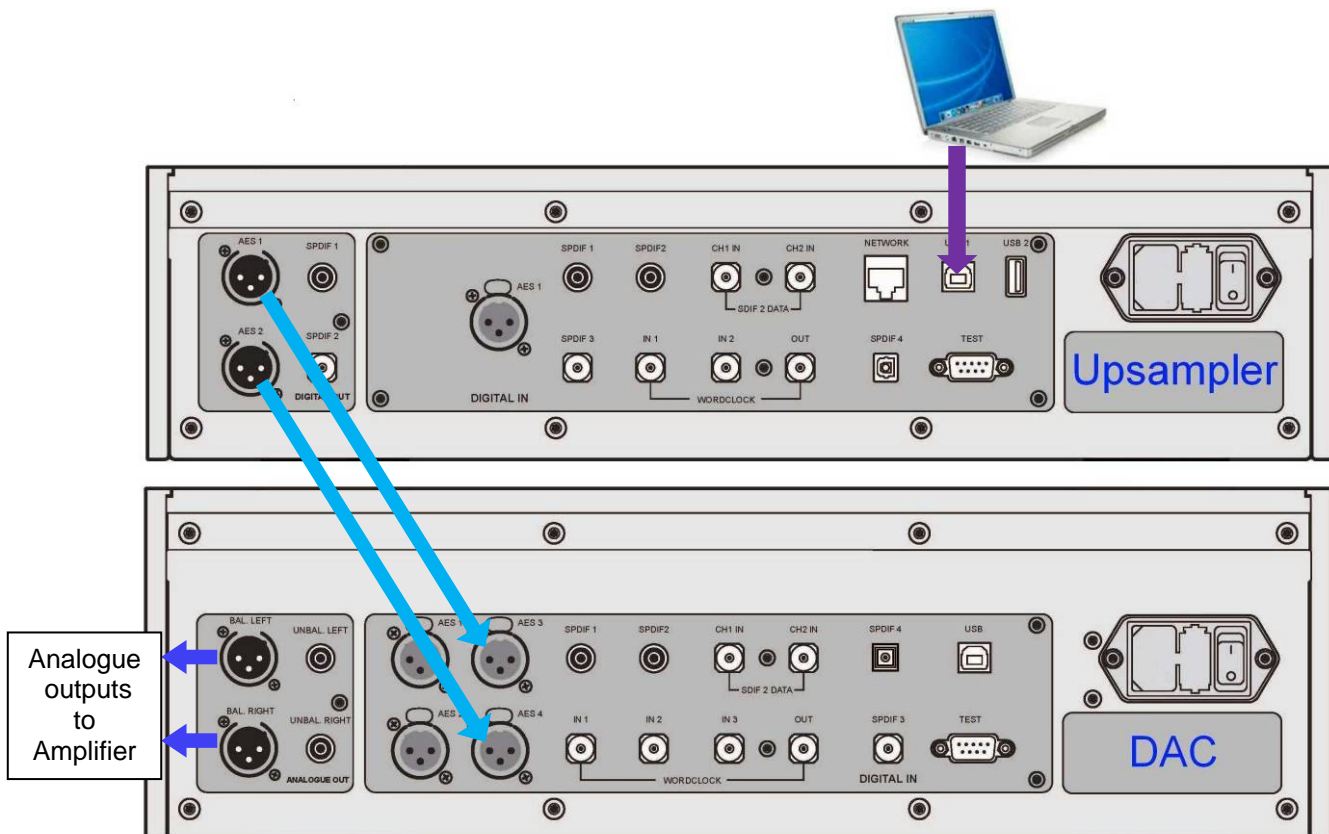

Figure 4 – Using a Vivaldi Upsampler and DAC with a laptop

A word about Music Playing Software

There are countless programs that can play music on Windows and Apple Mac OSX PCs. Unfortunately, not all of them present the data completely unprocessed to the USB ports. For example, Windows Media Player re-samples all data to 24 bits, albeit at the original sample rate, while iTunes rate converts data as necessary to the output sample rate set in the OSX Audio MIDI Set-up panel.

With such a proliferation of playing software, and with updates being issued daily, it is impossible for dCS to be fully up-to-date with the behaviour and performance of all programs. If you have questions or problems, we would urge you to take them up with your software vendor. Different programs operate very differently and it is well worth finding out exactly how your particular program processes the audio.

We suggest that you use a premium music streaming program, such as JRiver Media Center (Windows or Mac) or Audirvana (Mac), rather than relying on the software bundled with the operating system.

Selecting the Vivaldi Upsampler as your Audio Output device

Whichever program you are using to play your music, your computer may not automatically select your Vivaldi Upsampler as the preferred playback device. Once you have connected the Upsampler and switched it on, you can correct this as follows:

Mac OSX™ - Open **Finder**, click on the **Go** tab and select **Utilities** > **Audio MIDI Setup**. Select **dCS Vivaldi USB ...** from the list on the left-hand side, right-click on it, and choose **“Use this device for sound output”** from the drop down list. Set the **Format** to **384000.0Hz** and **2ch-24bit Integer**. Close **Audio MIDI Setup**.

Windows 10™ / Windows 8.1™ / Windows 7™ / Windows Vista™ - Go to **Start > Control Panel > Hardware and Sound > Sound**. In the **Playback** panel, right-click **dCS Vivaldi Upsampler Audio** and choose **Set as Default Communication Device**. Click the **Enhancements** tab and check **Disable all enhancements**. Select the **Advanced** tab, choose **24 bit, 192000 Hz (Studio Quality)** from the drop-down box. Check the 2 boxes under **Exclusive Mode**, click **OK** and **OK** again to close the **Sound** panel.



This is basic set up information only.

Open your streaming program, select the **Vivaldi Upsampler** in the **Options** or **Preferences** panel and play some music.

STEP 5 – UPnP Network Connection

UPnP (Universal Plug and Play) is a set of protocols designed to allow consumer devices to interact over a network. Vivaldi Upsampler complies with the UPnP AV protocol, enabling it to communicate with other non-dCS devices, provided they also comply with this protocol.

A network streaming system is made up of three standard UPnP components: UPnP **Control Point**, UPnP **Media Renderer** and UPnP **Media Server**. A system may consist of one or more of each of these components. In such a system, all of the media (songs, tracks, videos etc) is stored on the server. This storage device can be a NAS or a Computer. The control point (e.g. a tablet or smart phone) requests the address of a particular item of media from the server (e.g. a NAS drive). It then passes this address to the renderer (e.g. a Vivaldi Upsampler) to play. The renderer directly retrieves the item from the specified address on the server, decodes and plays the media as it arrives over the network from the server.

Enabling network streaming of audio using a Vivaldi Upsampler relies on the presence of standard network infrastructure in your system. A description of the network will not be discussed in this manual but at a minimum the following components are required for system setup: Router, Computer, Vivaldi Upsampler, NAS, Wireless access point (WAP), Wireless control.

Please note that Ethernet cables are required to connect the devices and the NAS must have UPnP media server software (e.g. Twonky, Miniserver, Asset) installed. If the UPnP control point is having problems seeing the UPnP media server or the UPnP media renderer, you might need to disable IGMP snooping in the router or enable UPnP discovery mode in the router or the NAS drive.

The dCS Vivaldi App is a control point application that will allow users to view / select available renderers, view / select available media servers and browse / select / playback music via the Vivaldi Upsampler. The dCS Vivaldi App is currently available for iOS.

Compatibility

The Vivaldi Upsampler and the App are compatible with:

- iPad 2 or later.
- iPhone 4S or later.
- iPod Touch 5th Generation or later.

Vivaldi 2.0 app version 1.2.6 has been tested with iOS 9.3.

Basic set-up

- Connect the system as shown below.



Figure 5 – Using a Vivaldi Upsampler and DAC with a NAS

- Download the dCS Vivaldi 2.0 App from the App Store to your iPad / iPhone / iPod and install it.
- Connect the Upsampler's **Network** interface to the Ethernet network.
- Select the Upsampler's **Network** input.



Open the Upsampler's Menu and select **Settings > Sync Mode > Master Mode**. (This is the basic setup without a Master Clock.)



Connect the Upsampler's **AES1+2** output (or **AES1**) to the Vivaldi DAC's **AES3+4** input (or **AES3**), as this input will accept tunnel commands from the Upsampler. (Also see page **26**.)



Open the DAC's Menu and select **Settings > Sync Mode > Audio**. (This is the basic setup without a Master Clock.)

- Connect the control device (e.g. iPad) to the network.
- Launch the *dCS* Vivaldi 2.0 App.
- The system will search for compatible Vivaldi Upsamplers. When the Device list appears, tap the Upsampler icon in the zone you want to use.
- Tap **Configure** to change the Upsampler's settings, find information about the unit or use the test features. Tap **Preferences** to optimise the unit for your use. You can add Spotify or Tidal to your Favourites on the **Preferences** page.

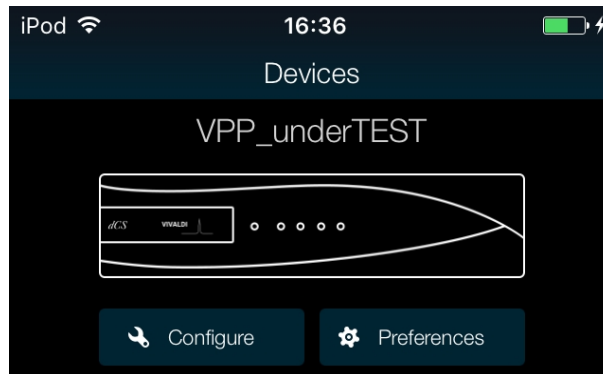

- Tap the picture of the Upsampler to go to the Home page.
- Tap **UPnP** to select a NAS on the same network. (Alternatively, tap USB to select a flash drive connected to the **USB2** port.)

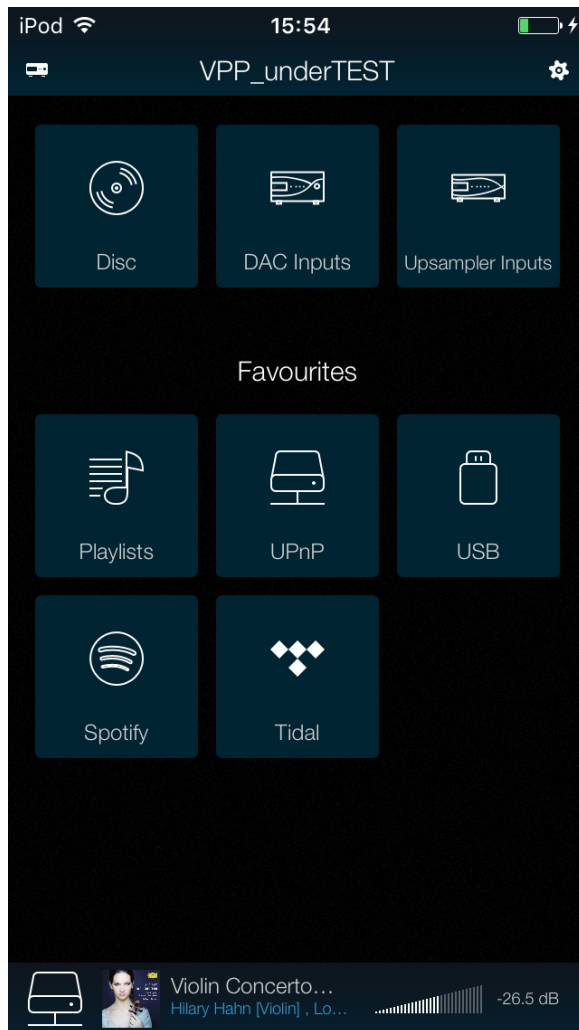

The icon in the lower left corner indicates the selected input (Network in this case).



- Tap on a server to select it.
- Select the browsing method (Artist, Album, etc.).



- Navigate down to the track list.



- Choose either **All Tracks** to play the whole album or **Selected Tracks** and then tap on the tracks you want to play.
- Tap one of the action buttons:



Cancel the Queue and play now.



Add to the start of the Queue.



Add to the Queue after the current track.



Add to the end of the Queue.



Add to a Playlist.



The Player's Network input is automatically selected when the track starts playing.



Tap the back icon if you want to return to the previous page.



Tap the Home icon if you want to return to the Home page.



Tap the Network icon at the bottom of the screen to see the track that is currently playing.

• Current track:

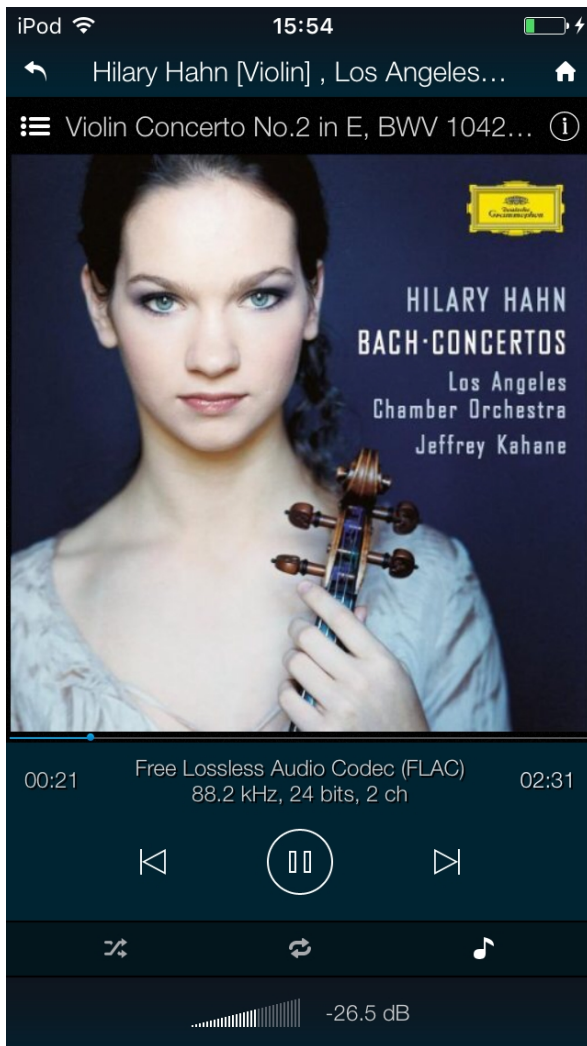

Shuffle tracks.



Repeat track.



Change phase.

The Volume control requires the 3-way RS232 cable to be fitted, see page 26.



Adjust volume.

Set the volume slider as required, then tap the white **x** to close the volume panel.

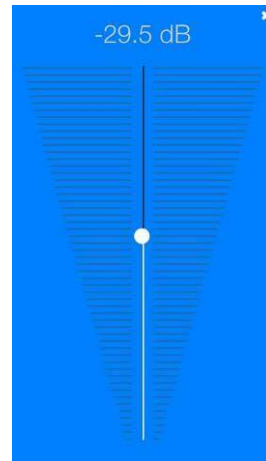

Tap here to go to the **Play Queue** page.



Tap **Home** and then **Playlists** to go to the **Playlists** page.

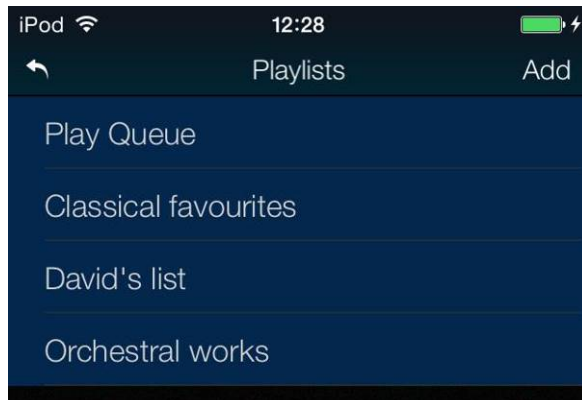

Tap on a list or the **Play Queue** to open it.

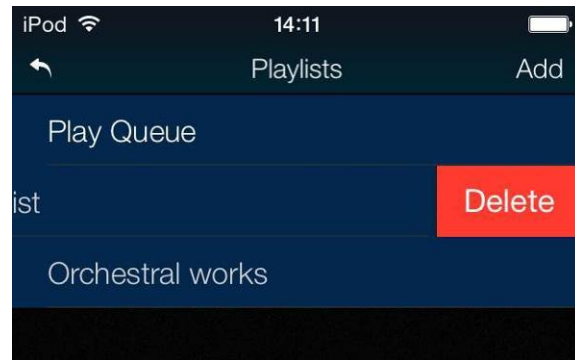

To delete a Playlist, swipe it to the left and tap **Delete**.



Select a track and tap the **Play** icon to start playing it.



Tap here to save the Play Queue as a new Playlist, type a name and tap **OK**.



Tap this icon to start editing the open Play Queue or a Playlist.

To change the track order, drag tracks to the new position.



To delete tracks from a list, select them and then tap this icon.



When you have finished editing the list, tap the highlighted Edit icon again to de-select it.

While browsing albums, artists or tracks, you can search for some text in the list.

Tap on the Search icon – the keyboard will appear.



Type the text you want to search for (or just part of it).

If you have a large music library, the search may take some time. Please be patient and take care not to type a letter twice.

When the matching entries are displayed, drag downwards in the list to close the keyboard. Select the track you want and either play it or add it to a playlist.

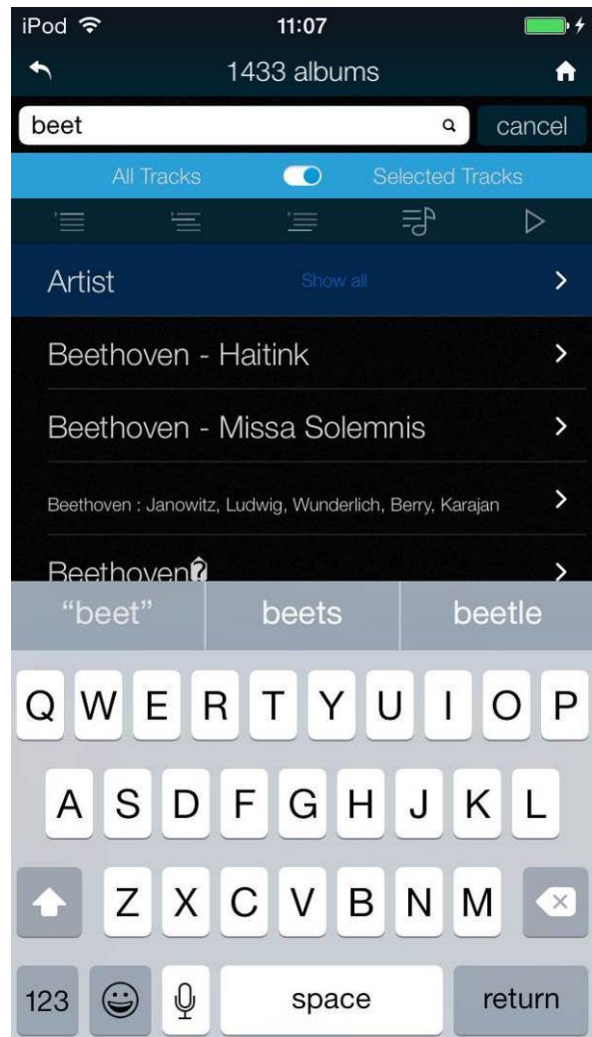

The current track screen of the iPad app in landscape mode displays the album art / metadata, playback control and the PlayQueue.

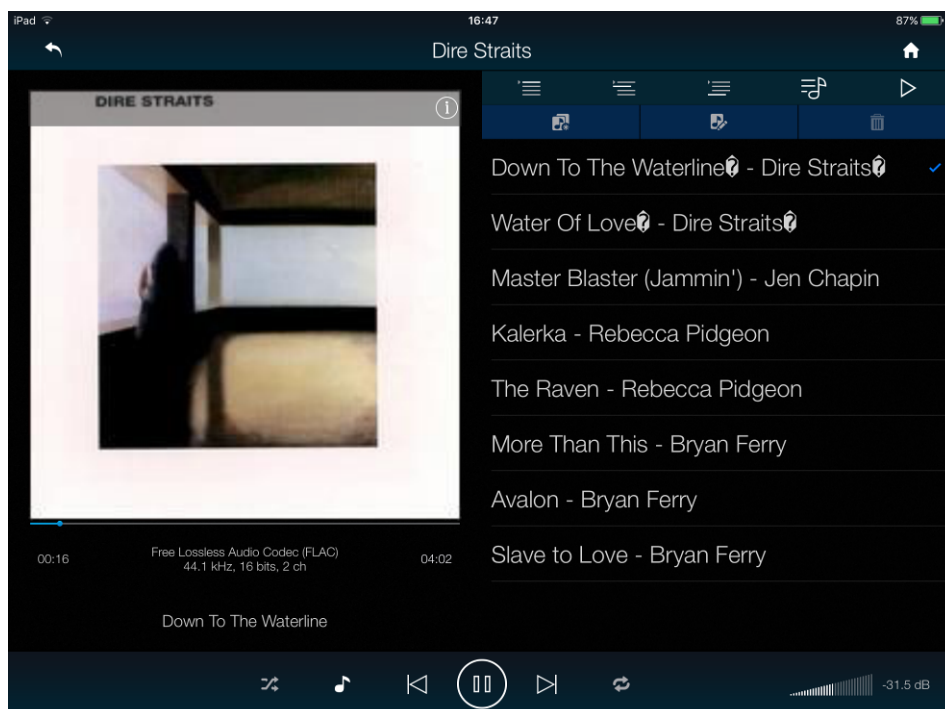

Playing music with AirPlay

When the Upsampler is connected to a network, music can be streamed from an Apple device via AirPlay to the Upsampler. When AirPlay is active, the Upsampler's Network input is automatically selected.



The Vivaldi DAC's lower Output Level settings are intended to prevent accidents when driving the amplifiers directly and AirPlay is in use, as the volume set by the sending device can be very high.

Using the Vivaldi Upsampler with Spotify Connect



Spotify lets you listen to millions of songs – the artists you love, the latest hits and discoveries just for you.

If you are a Spotify user, you can control the Upsampler using your Spotify App.

1. Connect the Upsampler to the same Wi-Fi network as your phone, tablet or PC running the Spotify app.
2. Open the Spotify app and play any song.
3. Tap the song image at the bottom of the screen.
4. Tap the Connect icon. 
5. Pick the Vivaldi Upsampler from the list.

For further information on how to set up and use Spotify Connect, please visit

www.spotify.com/connect

Licenses

The Spotify software is subject to third-party licenses found here:

www.spotify.com/connect/third-party-licenses.

Using the Vivaldi Upsampler with Tidal

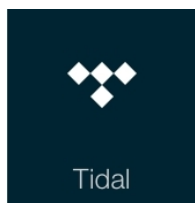

If you have a Tidal account, go to the app's **Configuration > Online Service > Tidal** page, enter your account details and tap **Add**. Make sure you have checked **Tidal** in the **Preference > Favourite Inputs** page. Go to the **Home** page and tap the **Tidal** pad to access music over the internet through Tidal.

To create and store Tidal playlists, please use the Tidal app directly.

www.tidal.com

Using the Vivaldi Upsampler with Roon



Software version 2.01 is Roon Ready. If you have a Roon account, you need to install Roon server on your NAS drive or in a networked PC. You can then use Roon remote to control playback. Roon requires a fairly powerful processor, so please check the Roon website when choosing a NAS drive.

<https://roonlabs.com/>

STEP 6 - Using the Vivaldi 2.0 app as a remote control

You can use the app to change inputs or settings by tapping the **Home** page's **Upsampler Inputs**, **DAC Inputs** and **Configuration** pads. Commands are sent to the DAC are sent via the **AES3** interface.



In order to control the Transport and read information from the DAC, it is necessary to fit the 3-way RS232 cable (supplied with the Upsampler Plus) to the system as shown below. Note that the 3 connectors are labelled VTT (for the Transport), VPP (for the Upsampler) and VDC (for the DAC), each must be fitted to the correct unit.

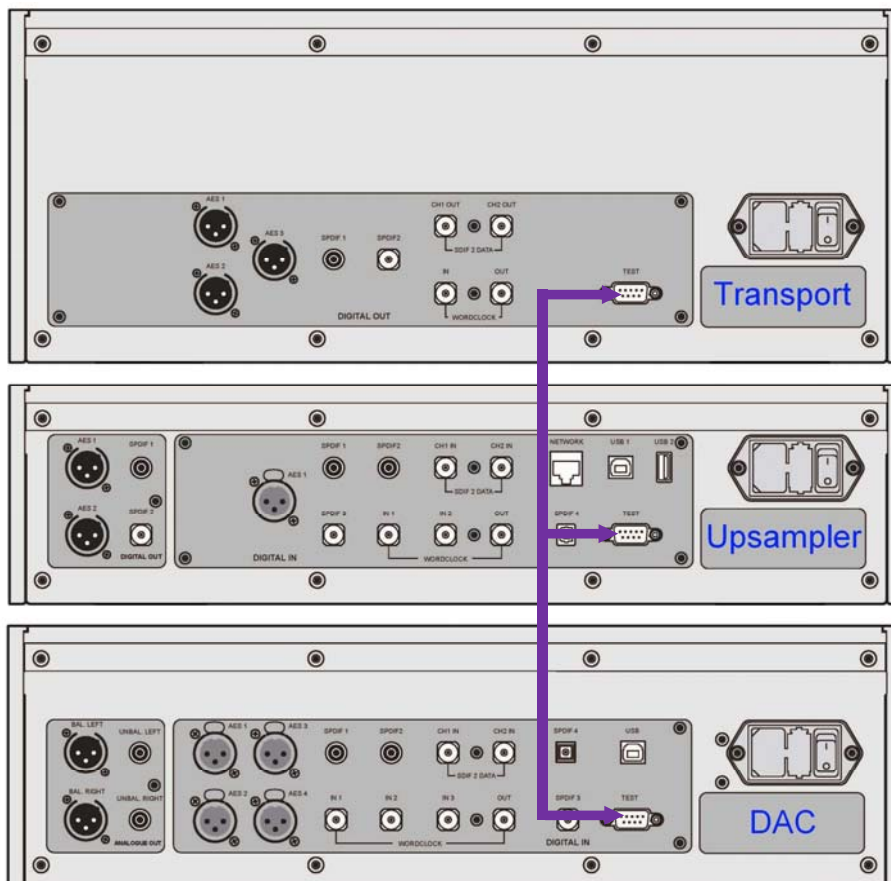

The **Settings > RS232 Mode** menu page on all 3 units must be set to **Binary**.

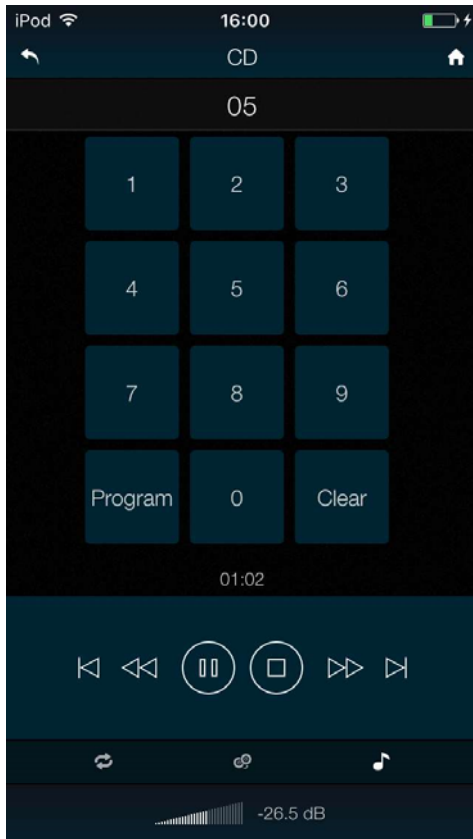

Transport controls

The CD control panel works in the usual way.

To program a track sequence, stop playback, tap the Program pad, enter a track number (e.g. 5 or 05), enter the rest of the sequence and tap Play.

The Transport will display (for example) **8PGM3**, which means there are 3 tracks in the sequence and the last is track 8.

To remove the last track from the sequence, stop playback and tap Clear. Tap Program again to cancel the sequence and play tracks in the usual way. Opening the CD tray cancels Program mode also.

The 3 pads above the Volume taper are:

- Repeat Track / Repeat Disk / Repeat Off.
- Play the other layer of a CD/SACD hybrid disc.
- Change Phase.

Tap  on the Home page to access:

Unit Settings

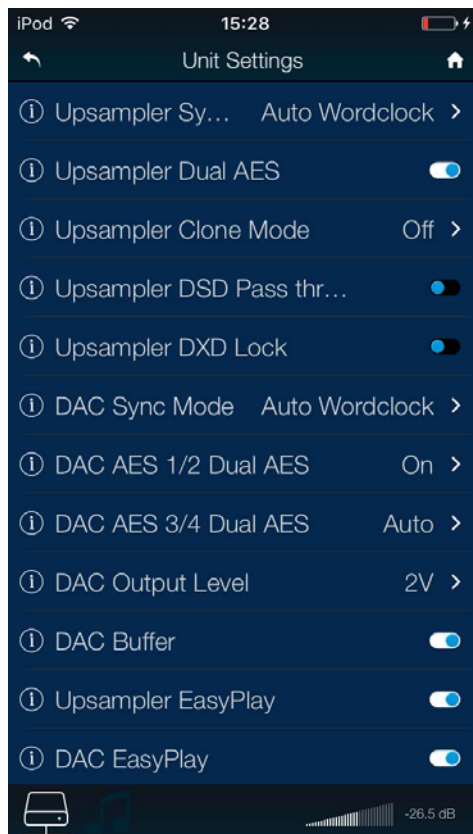

Playback Controls

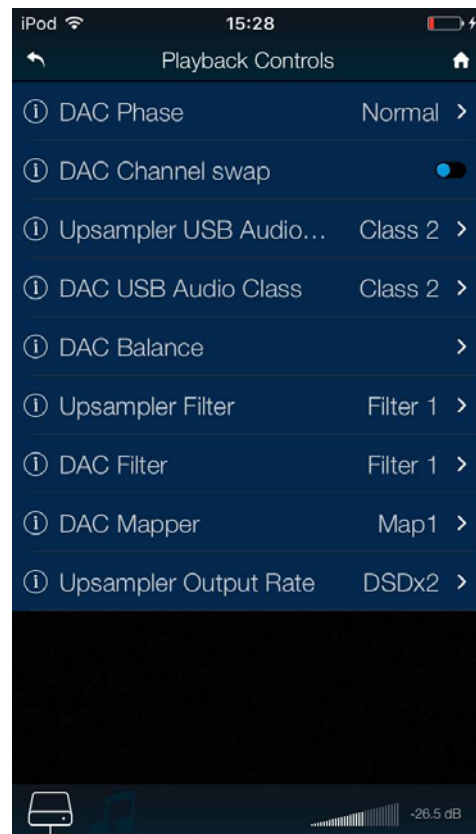

STEP 7 – Using the USB2 input

You can play compatible music files stored on a flash drive that has been formatted as FAT16 or FAT32. Drives formatted as NTFS or other formats are not compatible. A USB hard disc drive connected to the USB2 port may also be usable, provided the power demands are not too high and the format is compatible.

- Connect the drive to the **USB2** port.
- Hold down the **Menu** button for 2 seconds to open the browser. **Waiting for USB device** may be displayed for a few seconds.
- The files and sub-directories in the root directory will be listed on the display. Use the **▶** and **◀** buttons to move the blue highlight. (The blue highlight is a cursor, it does not move when the Upsampler starts playing the next track.)

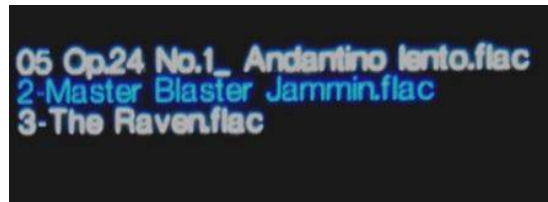

- Press the **Menu** button to either start playing a file or to move into a sub-directory.
- If you need to navigate back up the directory structure, press the **Output** button.
- Press the **Power** button briefly to close the browser.

The operation of the front panel controls returns to normal. The name of the track, the play icon and the track elapsed time will be displayed.

The Upsampler will play all the files in that directory in the sequence they appear on the flash drive and then stop.

- Use the remote control's **Previous Track**, **Next Track**, **Play/Pause** and **Stop/Eject** buttons to control playback.
- To select a different directory or re-start playback, open the browser again.



Do not try to play non-audio files, as this can cause the interface to malfunction. If you do this by accident, re-boot the Upsampler.



When the Upsampler is connected to a network, you can use a mobile device running the *dCS Vivaldi 2.0* App to control playback from the flash drive - see **Step 5** for details. The Upsampler treats the flash drive as a network drive.



The **USB2** interface is not suitable for direct connection to an Apple device. Please use AirPlay instead.

STEP 8 – Setting the Sync Mode for Computer Audio sources

Using the DAC in Universal Master Mode

You can improve the quality of playback from the Upsampler's USB and Network interfaces by locking the Upsampler to the DAC's clock. This does not work well in standard Master Mode as the sample rate may change between 44.1k-related rates and 48k-related rates. To solve this problem, the Vivaldi DAC with software v1.10 (or later) has a Universal Master Mode which produces a 38.4kHz word clock from which either base rate can be derived easily. Vivaldi Upsampler v1.10 (or later) can lock to this frequency.

- Add a connection from the DAC's **Word Clock Out** output to the Upsampler's **Word Clock In1** as shown below. A PC is shown connecting to **USB1**, but the data source can be connected to **USB2** or the **Network** interface instead.

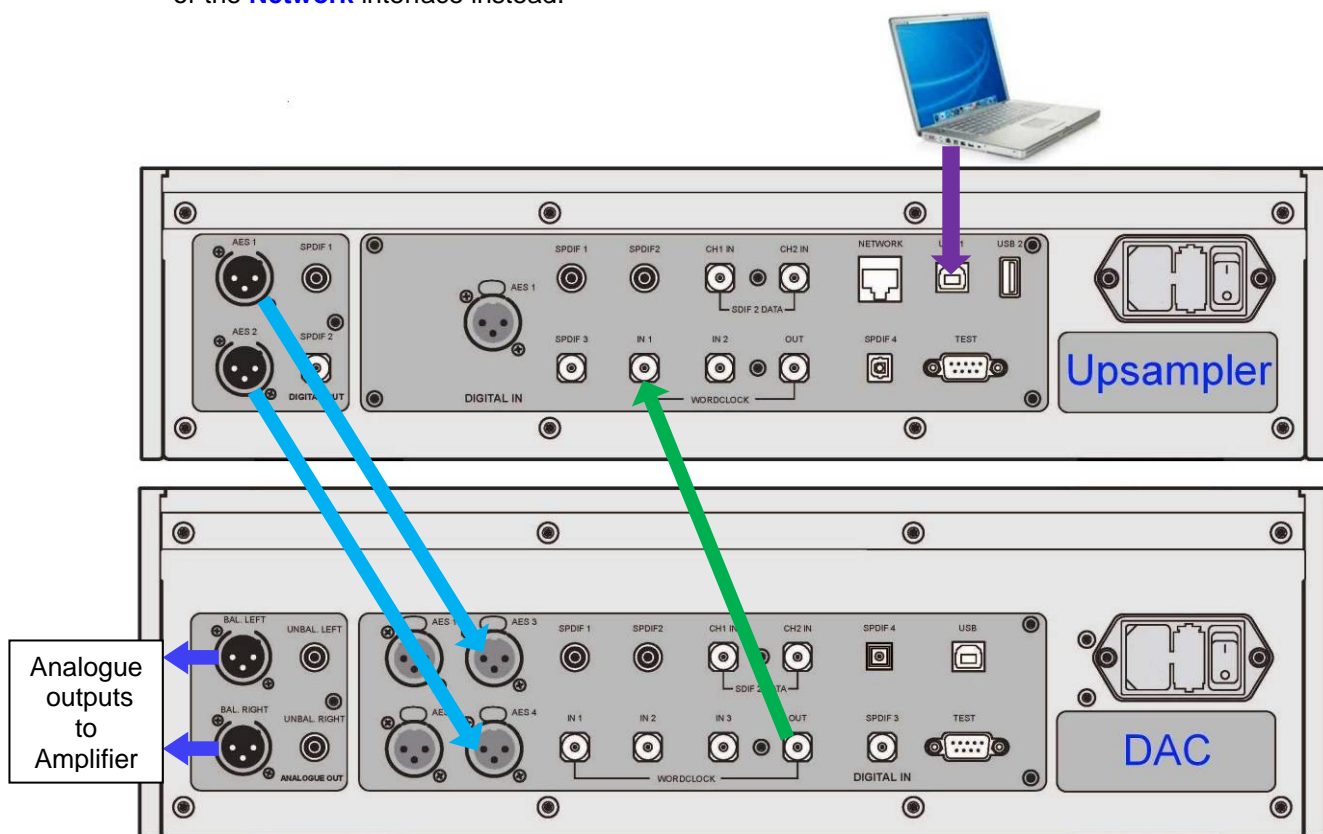

Figure 6 – Using a Vivaldi Upsampler and DAC In Universal Master Mode

- Select the Upsampler input you are using.
- Select the DAC's **AES3+4** input.



Open the DAC's Menu and select **Settings > Sync Mode > Universal Master Mode**.



Open the Upsampler's Menu and select **Settings > Sync Mode > Word Clock 1**.

The Upsampler will lock to the DAC's clock and will stay locked at any sample rate.

Using the DAC and Upsampler with a Master Clock

You can improve the sound quality further by connecting a Vivaldi Master Clock to your system as described on page [13](#).

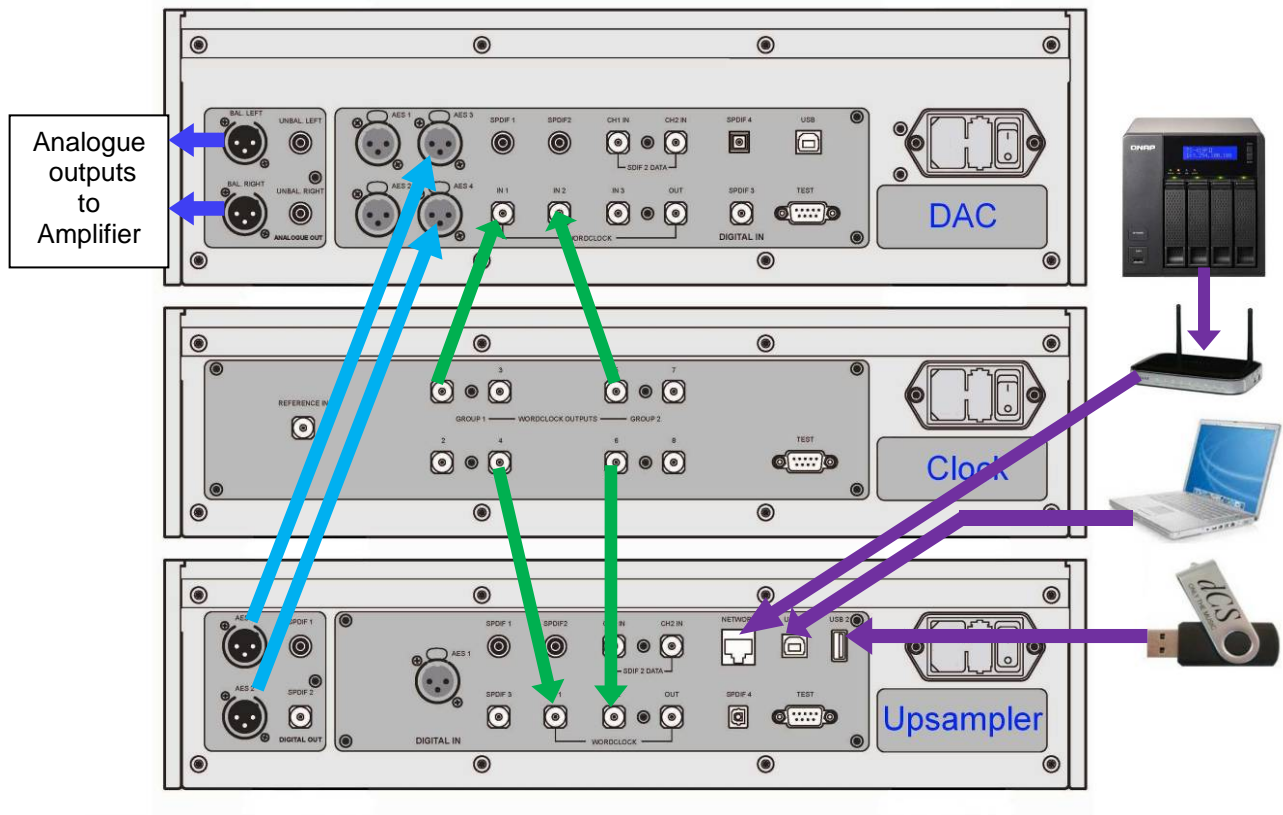

Figure 7 – Using a Vivaldi Upsampler and DAC with a Clock

- Set the Master Clock Group 1 Frequency to 44.1kHz and Group 2 Frequency to 48kHz.
- Set the Upsampler's input to the **USB1** or **Network** input as necessary.
- Set the DAC's input to **AES3+4**.



Set the **Settings > Sync mode** menu pages for the DAC and Upsampler to **Auto W1/W2**, and both units will automatically choose the clock that is synchronous with the data.



Remember to select the input before setting the **Sync Mode**.

The next step is crucial – sit back and enjoy the music.

Advanced options

Using the Web Client interface

To access the web client interface, open the [Upsampler's Information > Unit Status](#) menu page. Scroll to the third page and note the IP address of the Upsampler (192.168.0.3 in this example). Open a web browser in any device on the same network and point it to the Upsampler's IP address. The Main Page reports some information about the network. Tap Device Settings.

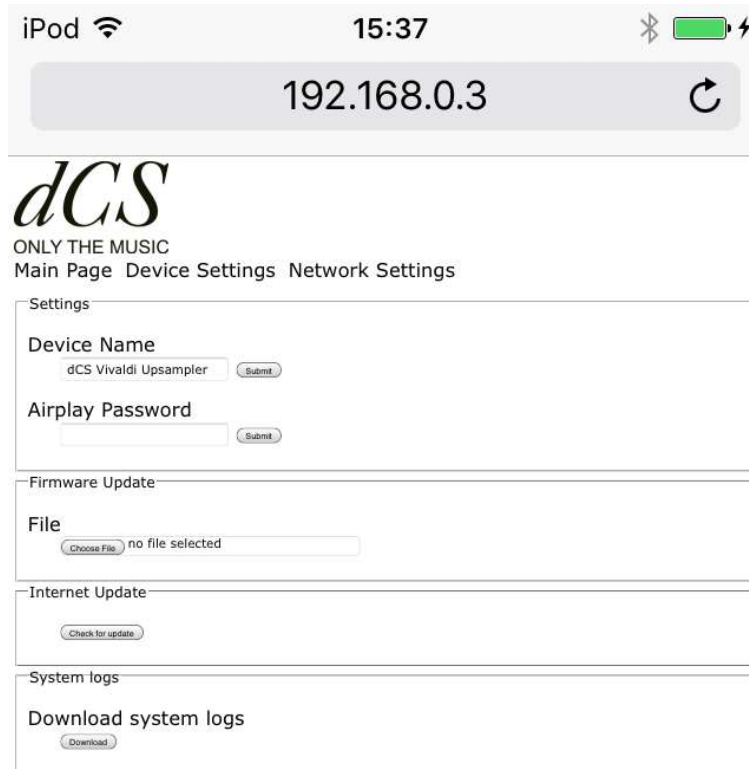

iPod 15:37

192.168.0.3

dCS
ONLY THE MUSIC
Main Page Device Settings Network Settings

Settings

Device Name
dCS Vivaldi Upsampler Submit

Airplay Password
Submit

Firmware Update

File
Choose File no file selected

Internet Update
Check for update

System logs
Download system logs
Download

Here you can:

- Change the **Device Name** so that you can identify different Upsamplers on the network.
- Enter the **AirPlay Password** if necessary.
- Load a Network **Firmware Update** from a file (this is rarely necessary).
- Check if an **Internet Update** is available from the update server on the internet and load it. (This is mainly for owners who are not using the Vivaldi 2.0 app.)

You can change the dynamic IP address to a fixed address on the **Network Settings** page.

Customising the input configuration

The Vivaldi Upsampler's inputs can be renamed to suit your particular system using a computer running a terminal emulator program. The Vivaldi DAC has the same feature. The procedure using a Windows PC with TeraTerm is described here, but other programs such as PuTTY or ZTerm could be used. If you have difficulty with this, please ask your Dealer for help.

- Power up the Upsampler and a Windows PC.
- If no suitable terminal program (for example Hyperterminal) is already installed, download Tera Term from <http://en.sourceforge.jp/projects/ttssh2/releases/> and install it on your PC. (If the link is broken, please search for the latest version of Tera Term online.)



Set the Upsampler's **Settings > RS232** menu page to the **Text** option.

- Use a USB-to-RS232 adapter cable to connect the Upsampler's **Test** port to one of the PC's USB ports.
- Run ttermpro.exe.
- Click the **Serial** button – Tera Term will automatically select the port connected to the Upsampler. Click **OK**.
- Click Setup > Serial Port, set the Baud rate to 4800 and click OK.

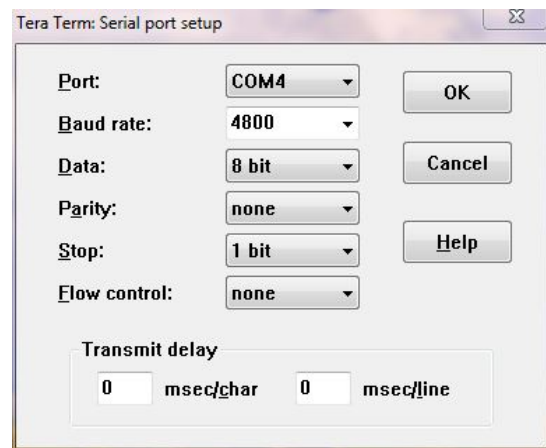

- In the terminal window, type the command: **NAME n = newname** where:
 - **n** is the number corresponding to the standard input name in the list below:

AES	0	SPDIF1	1	SPDIF2	2
SPDIF3	3	Toslink	4	SDIF-2	5
USB1	6	USB2	7	Network	9
 - **newname** is the personalised name you want to use for that input, such as CD, TV or COMPUTER. It can be up to 8 characters long, consisting of:

capital letters A-Z, numbers 0-9 or + - / = . : ? ! @ &
- Press **Enter**.

For example:

- to rename the **AES** input to CD, type: **NAME 0 = CD** and press enter.
- to rename the **Toslink** input to TV, type: **NAME 4 = TV** and press enter.



Later on, if you want to revert to the standard input names (**AES**, **SPDIF1**, etc.), select the **Configuration > Reset Input Names** menu page. Your customised input names will be permanently deleted.

FRONT PANEL



Figure 8 – Front panel

Remote Control Receiver

Aim the remote control handset towards the receiver (A) for best sensitivity.

Display

In normal use, the selected input appears at the top left corner of the display (B). To the right of this, the input word length / sample rate and output sample rate appear. The sample rates are replaced by **No Input** when a recognisable data stream is not detected.

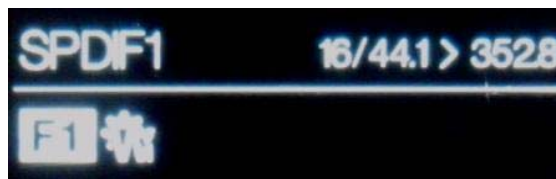

The Filter, Sync Mode and Clone icons appear on the bottom row.

While the Upsampler is streaming data via the **Network** or **USB2** inputs, the track name appears at the bottom of the display, with the play/pause icon and the elapsed track time at the right hand side.

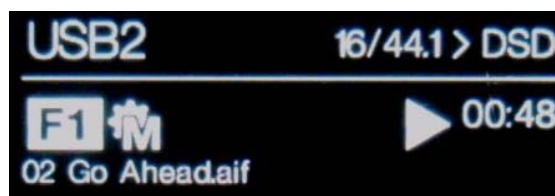

If the Upsampler is receiving a data stream in which the **NonAudio** flag has been set, the Upsampler will mute and display for example: **NA/44.1>DSD**. The Vivaldi Transport (v1.10 or later) sets the NonAudio flag when the CD tray opens and returns to Audio mode when playback starts.

Details of the menu displays are shown in the Menu section on page **39**.



To avoid unnecessary display wear, we recommend switching off or setting the unit to Sleep mode at the end of the listening session.

Power Button

To switch on, ensure the rear panel switch is set to **I** and press the **Power** button (C) on the front panel once. Note that the unit cannot be turned on from the remote control.

To set the unit to sleep mode, press the **Power** button once. The main display will turn off, the LED (D) beside the button will light, and the digital outputs will mute, but the unit will remain close to running temperature. Press again to return to normal operation.

To switch off, hold down the **Power** button for about 3 seconds until **SWITCHING OFF** appears on the display, then release it.

When the menu is open, press the **Power** button to close the menu.

When the browser is open, pressing the **Power** button briefly closes the browser and returns the front panel controls to their normal function.

Menu Button

Press the **Menu** button (E) to open the menu, select menu pages and change settings. See the Menu section on page 39 for information on using the menu features.

When the **USB2** input is selected and media connected, hold the **Menu** button down for 2 seconds to open the browser (see page 28). Use the **Menu** button to change to a sub-directory or select a file to play.

Filter Button

(F) The optional Filters give different trade-offs between impulse response and aliasing.

For most conversions, only **Filter 1** is available - a classic sharp filter. The amplitude is reduced by 0.1dB to match the other filters.

The best filter setting is a personal choice and may be related to the type of music.

The table below shows how many filter choices are available for each input / output combination.

		OUTPUT RATE										
		32k	44.1k	48k	88.2k	96k	176.4k	192k	352.8k	384k	DSD	DSDx2
INPUT RATE	32k	1	1	1	1	1	1	1	1	1	1	1
	44.1k		1	2	5	2	5	2	6	2	6	6
	48k			1	1	4	1	4	1	1	1	1
	88.2k				1	1	1	1	1	1	4	1
	96k					1	1	1	1	1	1	1
	176.4k						1	1	1	1	1	1
	192k							1	1	1	1	1
	352.8k								1		1	1
	384k									1		
	DSD										1	
	DSDx2											1

For conversions with 2 filters (currently all of these have a 44.1k input rate):

Filter 1 is a classic sharp filter.

Filter 2 is a very steep, long asymmetrical (sometimes called apodizing) filter which starts rolling off at 20kHz. This filter has no energy left in the output to exercise the DAC's filter, so there is no pre-ringing from the source and the DAC. This will improve the response of the DAC's reconstruction filter by removing some high frequency components that typically cause images in half-band filter DACs.

For conversions with 4 filters:

Filter 1 has the sharpest cut-off, and so has the poorest impulse response (transient performance) but the best alias rejection (removal of out-of-band frequencies).

Filters 2, 3 and **4** have progressively gentler cut-off, with less alias rejection.

For conversions with 5 filters (currently all of these have a 44.1k input rate):

Filters 1 – 4 are the same as for conversions with 4 filters.

Filter 5 is an asymmetrical design with non-linear phase and no pre-ringing.

For conversions with 6 filters (currently all of these have a 44.1k input rate):

Filters 1 – 4 are the same as for conversions with 4 filters.

Filter 5 is an asymmetrical design with non-linear phase and no pre-ringing.

Filter 6 is a long filter which has linear phase and pre-ringing.



The **Filter** button has no effect if an input / output rate combination with only 1 filter choice is selected, or if the Upsampler is not locked to a source.



“I don’t have time to listen to all these filters! Which ones do you suggest?”

Filters are definitely a personal choice, but we suggest the following:

- 44.1kS/s > 48, 96, 192 or 384kS/s - Filter 2 (asymmetrical)
- 44.1kS/s > 88.2, 176.4 or 352.8kS/s or DSD – Filter 5 (asymmetrical)
- 48kS/s > 96 or 192kS/s – Filters 2 or 3
- 88.2kS/s > DSD – Filters 2 or 3

The Upsampler remembers the last filter set for each sample rate conversion (not just each input rate).

When the menu is open, the **Filter** button changes to the ◀ button, used to page backwards through the menu.

When the browser is open, the **Filter** button scrolls up the file list.

Input Button

Press the **Input** button (G) to change the selected input, the input name in the top left corner of the display will change.



Inputs which are not connected to an active source do not appear in the list and so cannot be selected. This is an important change from previous versions.
The **Network** input is always selectable.

The source sample rate is automatically detected. The full input sequence is:

..., **AES, SPDIF1, SPDIF2, SPDIF3, Toslink, SDIF-2, USB1, Network,...**

When the menu is open, the **Input** button changes to the ▶ button, used to page forwards through the menu.

When the browser is open, the **Input** button scrolls down the file list.

Output Button

Use the **Output** button (H) to change the output sample rate, the new rate appears on the right side of the display. The output sample rate sequence is:

..., 32, 44.1, 48, 88.2, 96, 176.4, 192, 352.8, 384, DSD, DSDx2, 32, ...



The Vivaldi Upsampler does not feature down-sampling combinations (except from DSD).

Output sample rates that are lower than the input sample rate cannot be selected.

If the input rate changes so that it is higher than the output rate, the output rate will automatically change to match the input.

When the **DXD Mode** menu page is **On**, 352.8 and 384 are replaced in the sequence by DXD. In this mode, input data at 44.1, 88.2, 176.4 or 352.8kS/s or DSD is upsampled to 352.8, while input data at 32, 48, 96, 192 or 384kS/s is upsampled to 384kS/s.

When the browser is open, the **Output** button navigates up to the previous directory (if one exists).

REAR PANEL

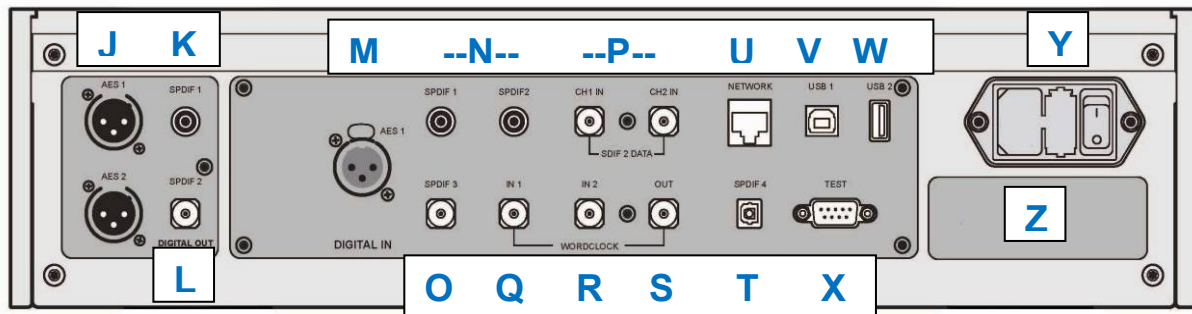

Figure 9 – Rear panel

Digital Outputs

All of the outputs consistent with the selected output mode are active at the same time.



The Vivaldi Upsampler generates 24-bit PCM data but it does not have facilities to reduce the word length to less than 24 bits. It will not give good results with older DACs (or other equipment) that cannot process 24-bit data. ALL dCS converters will accept 24-bit PCM data.

The **AES1** and **AES2** outputs (J) can be used individually at 32, 44.1, 48, 88.2, 96, 176.4 or 192kS/s or DSD/64 in DoP format, or as a Dual AES pair at 88.2, 96, 176.4, 192, 352.8 or 384kS/s or DSD/64 or DSD/128 in DoP format.



For Dual AES operation at 88.2, 96, 176.4 or 192kS/s or DSD/64, the **Settings > Dual AES** menu page must be set to **Dual AES On**, otherwise both outputs will carry single AES data. If the output rate is 352.8 or 384 or DSD/128, Dual AES mode is automatically selected.

2 SPDIF outputs are provided, **SPDIF1** on an RCA connector (K) and **SPDIF2** on a BNC connector (L). These outputs carry SPDIF data for output rates at 32, 44.1, 48, 88.2, 96, 176.4 or 192kS/s or DSD/64 in DoP format, even if **Dual AES** mode is **On**. They are disabled when the Output mode is 352.8kS/s or 384kS/s.

Digital Inputs

The standard PCM inputs are **AES** on a 3-way female XLR connector (M), **SPDIF1** & **SPDIF2** on RCA connectors (N), **SPDIF3** on a BNC connector (O) and **SPDIF4** on a Toslink connector (T). The electrical inputs will accept up to 24-bit data at 32, 44.1, 48, 88.2, 96, 176.4 or 192kS/s or DSD/64 in DoP format. The Toslink input accepts data at up to 96kS/s and is not tested or guaranteed at higher sample rates.

The **SDIF** interface will accept PCM data at sample rates up to 96kS/s. The interface consists of two data inputs labelled **CH1** and **CH2** (P). Operation in SDIF mode requires that a word clock from the source is connected to the **Word Clock In1** or **In2** connector (Q). Note that the interface can fail to lock correctly if the data sample rate changes but the Word Clock does not.

Word Clock Input / Output

Either of the two **Word Clock In** connectors (Q & R) will accept standard word clock from the source equipment or a master clock at 32, 44.1, 48, 88.2, 96, 176.4 or 192kHz. The clock frequency **MUST** be an exact multiple of the data rate, otherwise the system will default to **Audio** sync. Use the **Settings > Sync mode** menu page (see page 42) to lock the selected input to the selected external word clock. The source **MUST** be locked to the same clock, otherwise the system will not be locked and periodic clicks or other undesirable noises or dropouts will be heard on the outputs.

The two **Word Clock In** inputs may be used individually, but to make operation easier, the Vivaldi Upsampler's **Sync mode** menu page features a **Word Clock 1-2 Auto** mode. In this mode you can connect a 44.1, 88.2 or 176.4kHz word clock to **Word Clock In1** and a 48, 96 or 192kHz word clock to **Word Clock In2**. With a source connected to another feed from the same Clock, the Upsampler can select the correct clock frequency.

When the USB or Network interfaces are in use, the Upsampler can be locked to a 38.4kHz clock generated by a Vivaldi DAC (v1.10 or later) set to **Universal Master Mode**.

The **Word Clock Out** connector (S) carries word clock as follows:

- Single wire output – Word Clock Output frequency is the same as the sample rate.
- Dual AES output 88.2 to 192kS/s - Word Clock Output frequency is 0.5 x the sample rate.
- Dual AES output 352.8 or 384kS/s - Word Clock Output frequency is 0.25 x the sample rate.
- DSD output modes - Word Clock Output frequency is 44.1kHz.

Word Clock is used for synchronisation only, it does not carry digital data.

Network Interface

The **Network** connection on an RJ45 socket (U) acts as a UPnP™ renderer, streaming music data from a NAS drive or a local computer over a standard Ethernet network. The Upsampler can stream music files at up to 24 bits / 384kS/s or DSD/128 under the control of a dCS Vivaldi App running on a suitable iPad, iPhone, iPod Touch, (see page 18) or other UPnP control point.



The RJ45 socket's contacts can be damaged by accidentally inserting the wrong connector (e.g. a USB type B or type A). To avoid this, we suggest leaving the dust cover fitted when not in use and fitting the RJ45 cable immediately after removal.

USB Interfaces

Both USB interfaces operate in True Asynchronous USB mode, which makes the Vivaldi Upsampler immune to clock jitter from the computer / sound server. The Upsampler uses its own internal clock or locks to the Master Clock connected to one of the **Word Clock** inputs. Feedback through the USB cable to the computer controls the data delivery rate.

The **USB1** interface on a 'B' type connector (V) will accept PCM data at up to 24 bits / 384kS/s from a Windows™ PC, Apple Mac™ PC or sound server equipped with a suitable USB2.0 interface. The interface will also accept DSD/64 or DSD/128 data packaged in DoP format.



We have tested this interface with several common formats running on Windows™ 10, Windows™ 8.1, Windows™ 7, Windows™ Vista (SP2) and Apple Mac™ OSX 10.10 with various PCM streaming programs but we cannot accept responsibility for correct operation with all source devices, operating systems or software.



The **Settings > USB Class** menu page can set the interface to **Class 1** (up to 96kS/s without a special driver) or **Class 2** (up to 384kS/s, no driver is required for OSX 10.6.3 onwards, the dCS USB Class 2 driver is required for Windows).



Operation at 352.8 or 384kS/s on Windows PCs requires the 2016 version of the dCS USB Class 2 Driver. If you have updated your Upsampler software from v1.xx, un-install any earlier version of the Driver from your Windows PC, download the updated Driver from www.dcsLtd.co.uk and install it.

The **USB2** interface (W) on an 'A' type connector can stream PCM music files in most popular formats at up to 24 bits / 384kS/s or up to DSD/128 from a USB Flash Drive. With a Flash Drive connected, a basic browser (see page 28) navigates to the music files and selects the file to be played. After closing the browser, the name of the file is displayed, with a Play or Pause icon and the elapsed playing time.

Mains-powered USB hard disk drives in FAT16 or FAT32 format may be used in the same way. The interface will not read drives in NTFS format or other formats.

Test interface

The **Test** interface (X) is an RS232 interface with two modes, set by the **Settings > RS232** menu page.

- **B**inary mode is used to remotely control the unit during automated production testing at dCS.
- **T**ext mode is for use with a household automation system. If you would like to use this mode, please download the list of remote control commands from www.dcsLtd.co.uk.

The interface is designed to be used with a "straight through" cable, wired pin 1 to pin 1, etc.

The pin connections are:

- Pin 2 – dCS unit transmit
- Pin 3 – dCS unit receive
- Pin 5 – ground
- Shell – cable screen & drain wire

Mains inlet

Power is connected via a standard IEC320 connector (Y), protected by a fuse and isolated by a 2-pole power switch.

Label

The label (Z) states the unit's serial number and the nominal voltage to which the unit is set. It is important to quote the serial number if you need assistance.

THE MENU

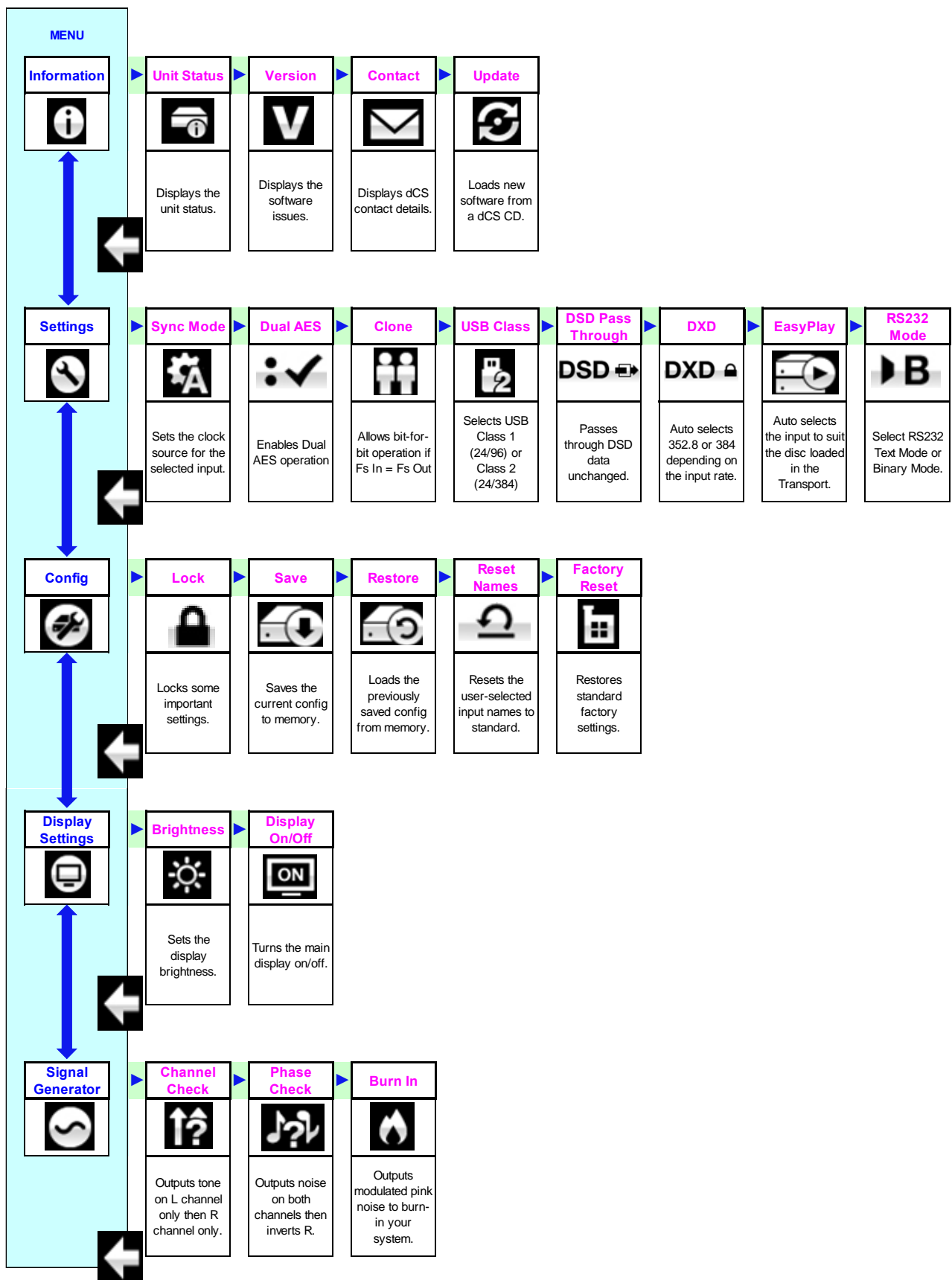

Figure 10 – The menu sequence

Using the Menu

The menu gives the user access to a range of additional features. It also allows new features and performance enhancements to be added later by software updates.

The menu is controlled by four buttons.

- Press the **MENU** button to open the menu or select a setting.
- Press the **▶** button to page forward through the menu.
- Press the **◀** button pages backward through the menu.
- Press the **POWER** button to close the menu or just wait 10 seconds.



Use the Menu Guide sheet to help you find the right menu page.

Each unit in the range has either four or five top-level menu pages:



The **INFORMATION** menu gives unit set-up details, software issues, serial number and contact details.



Each model has a different **SETTINGS** menu, which allows you to set some features that are not directly accessible from the front panel.



The **CONFIGURATION** menu allows you to lock important settings, save a standard setup and reset the unit.



The **DISPLAY SETTINGS** menu is used to adjust the display.



The **SIGNAL GENERATOR** menu (featured on the Transport, Upsampler and DAC only) contains test and set-up routines.

Use the **▶** button to move the blue highlight to the menu you want, then press the **MENU** button to select it. The next menu level down is displayed. Use the **▶** button to move the highlight to the menu page you want, then press the **MENU** button to display the information or change the setting.



Select the return icon to go back to the previous menu level.

INFORMATION Menu

Unit Status



The **Unit Status** page displays:

- The long version of the serial number, including the hardware configuration code.
- Internal temperature°C
- Each input and the sample rate detected on that inputS/s
- The **USB1** Audio Class setting.
- Each Word Clock input and the clock frequency detected on that inputHz.
- Network address and renderer name.

Use the ◀ ▶ buttons to scroll up or down the list. This page does not time out, press the **Menu** button to exit.



If your system is not behaving as you expect, the **Unit Status** pages can help you find set-up or connection errors.

Version



The **Version** page displays the software versions loaded in the unit. Please have this information ready if you contact your dealer for any reason:

- Control Board: 2.0x (this is the main software version)
- Front Panel: 2.0x
- Interface Board: 2.0x
- Network: xxx

This page does not time out, press the **Menu** button to exit.

Contact



The **Contact** page displays *dCS* web-site URL and support email address. This page does not time out, press the **Menu** button to exit.

If you have any difficulty, please contact your dealer for help first.

Update



The **Update** feature allows you to load new Control Board and Front Panel software into your system from any STANDARD CD player / transport or from a computer streaming bit-perfect data via the **USB1** interface. Note that some non-Red-Book CD transports change the digital data and cannot be used to download new software. Please follow the instructions supplied with the update disc carefully.



If you accidentally start an Update, do not worry. The unit will automatically detect it is not receiving updated software and will abort the process. The software will not have been changed.



Note that the **Update** feature is not recommended for the Upsampler as it will not update the Interface Board or the Network Board. To perform a full update, please connect the Upsampler to the internet and use the control app's **Information > Version > Check for Updates** feature.

UPSAMPLER SETTINGS Menu

Sync Mode

This page sets the clocking for the digital input that is currently selected. The options are:



Audio – The Upsampler extracts the clock from the data stream connected to the selected digital input and locks to it. Use this setting for sources that do not have a suitable Word Clock input. This arrangement does NOT give the best jitter performance or the best sound quality. Sync to **Audio** is not available when the **SDIF-2**, **USB1**, **USB2**, or **Network** inputs are selected.



Master – If the **USB1**, **USB2** or **Network** inputs are selected but a Master Clock is not available, the Upsampler must be set to **Master** mode. In this mode, the Upsampler's internal clock controls the system timing.



Word Clock 1-2 Auto – This mode is designed for easy operation with a Vivaldi Clock, DAC and computer, where the data rate may keep changing. Connect the **Word Clock In1** input to a Clock output set to 44.1 or 88.2 or 176.4kHz and connect **Word Clock In2** input to a Clock output set to 48, 96 or 192kHz. The DAC's Word Clock inputs should be connected similarly. When the sample rate changes, the DAC and Upsampler will automatically select a Word Clock frequency that is synchronous with the data. The selected word clock is displayed.



Word Clock1 – The Upsampler locks to an external clock connected to the **Word Clock In1** Input.



Word Clock2 – The Upsampler locks to an external clock connected to the **Word Clock In2** Input.



If the Upsampler cannot find a word clock that is synchronous with the data, it will default to **Audio** sync (or **Master** mode for some inputs) and display the “Bad Clock” icon.



The Upsampler remembers the **Sync Mode** setting separately for each digital input. Select the required input before changing the **Sync Mode** setting.

Dual AES



The **Dual AES** menu page sets the output mode when the output sample rate is 88.2, 96, 176.4 or 192kS/s or DSD in DoP format ONLY. When set to **Dual AES On**, a stereo pair of data is split between the **AES1** and **AES2** outputs, they MUST be used together as a pair. Each wire runs at half the sample rate (44.1, 48, 88.2, 96 or 88.2kS/s respectively). The left channel data appears on the **AES1** output, the right channel data appears on the **AES2** output.



When set to **Dual AES Off**, both **AES1** and **AES2** outputs carry the same single AES data at the output sample rate. Using these together in **Dual AES Off** mode is NOT the same as a Dual AES pair.



When the output sample rate is set to 352.8 or 384kS/s or DSDx2, Single AES mode is not available, so Dual AES mode is automatically selected.

Clone Mode



With the **Clone Mode** page set to **Clone On** and the output sample rate set to be equal to the input sample rate, PCM data passes through the Upsampler unchanged (bit-perfect). So if 16-bit data is received, 16-bit data will be output. The Clone icon appears on the display when Clone Mode is on.

If the input and output sample rates change so that they no longer match, the unit will stop cloning.

This mode is useful when passing HDCD data through unchanged to a (non-dCS) HDCD converter, or for updating a dCS unit via the Upsampler.



Set to **Clone Lock**, the output rate automatically changes to match any change in the input rate, locking the unit in clone mode. The Clone Lock icon appears on the display.



Set to **Clone Off**, the unit upsamples as directed by the control setting and so the data is changed. This is the usual setting.



Clone Mode is not available if the output rate is 352.8 or 384kS/s or DSD (use **DSD Pass-Through**).

Filters are disabled in Clone Mode, as filtering prevents bit-perfect operation.

USB Class



Set to **Class 1**, the **USB1** interface will operate with Mac PCs running OSX 10.5 onwards or Windows PCs at sample rates up to 96kS/s.



Set to **Class 2**, the **USB1** interface will operate with Mac PCs running OSX 10.6 onwards at sample rates up to 384kS/s or DSD/128. Class 2 operation with Windows PCs requires that the dCS USB Class 2 driver is loaded.

After changing the USB Class, wait for 10 seconds while the correct software is loaded.



Note that the **USB1** interface will not be detected by a computer if the unit is set to **Class 2** and a suitable driver is not available.

DSD Pass-Through





With **DSD Pass Through** set to **On**, when the data received on the selected input changes to DSD, it is passed through to the output unchanged. If the data format changes to PCM, the data is upsampled to the output rate previously set.



With **DSD Pass Through** set to **Off**, the output rate for PCM and DSD is set by the **Output** button.

DXD Mode

DXD  With **DXD Mode** set to **On**, 352.8 & 384kS/s disappear from the list of Output Rate choices, and are replaced by DXD. With DXD selected, input data that is a multiple of 44.1kS/s (including DSD) is upsampled to 24/352.8, while input data that is a multiple of 48kS/s is upsampled to 24/384.

DXD  With **DXD Mode** set to **Off**, 352.8kS/s and 384kS/s reappear in the list.

EasyPlay

Set to **On**, if the Vivaldi Transport's **AES3** output is connected to the Upsampler's **AES** input, the action of loading a CD causes the Upsampler's input to change to **AES**. If the disc is an SACD, the input does not change.



With **EasyPlay** set to **Off**, automatic input selection is disabled.

RS232 Mode

This sets the RS232 interface to either **Text** mode for use with 3rd-party control systems or...



...dCS production **Binary** mode, which is intended for factory use.

Set the **RS232 Mode** to **Binary** when using the Vivaldi 2.0 app to control the system via the 3-way RS232 cable.

CONFIGURATION Menu

Settings Lock



When set to **Locked**, this icon is displayed and the following settings cannot be changed:

- **Sync Mode** setting for all inputs
- **Dual AES** output setting
- **Output Rate** setting
- **DSD Pass-through**
- **DXD Lock**
- **USB Class**
- **RS232 Mode**
- **Save Configuration** is disabled
- **Restore Configuration** is disabled
- **Factory Reset** is disabled



Set to **Unlocked** if you need to change these settings.

Save Configuration



Once the unit is set up the way you want it, select **Save** to store the settings in memory. If you deliberately change the setup later and want to keep it, select **Save** again to store the changes.

Restore Configuration



If the unit settings are accidentally changed, select **Restore** to reload the settings you saved earlier.

Reset Input Names



If the inputs have been renamed from a computer, this page resets them to the original names: **AES**, **SPDIF1**, etc.

Factory Reset



This page resets the unit to standard settings. These are:

- **Sync Mode** to **Audio**, except
- **USB1** & **Network** sync to **Master**
- **SDIF-2** sync to **Word Clock In1**
- **Input** to **AES**
- **Output** sample rate to 192kS/s
- **Dual AES** mode to **Dual**
- **Clone mode** to **Clone-Off**.
- **RS232** mode to **Binary**.
- **Brightness** to maximum.
- **Display** to **On**.

DISPLAY SETTINGS Menu

Brightness



Set the display **Brightness** to a comfortable level using the ◀ or ▶ buttons.

Display On/Off



This page is usually set to **On**.



When set to **Off** and the menu closes, the display will turn off after a few seconds. The display will turn on briefly when a control setting is changed. The display will stay on if the unit is not locked or is muted.

GENERATOR Menu

Channel Check



A routine to test the system for swapped channels. A tone is output on the left channel only while the display shows **Left**, then the right channel only while the display shows **Right**. If these are the wrong way around, the left and right channels are swapped somewhere in your system. This test is not affected by the **Channel Swap** menu page setting.

Phase Check



A routine to test the system for phase reversals. Noise is output in phase on both channels while the display shows **In Phase**. Press the **Menu** button, the noise on the right channel is inverted while the display shows **Out of Phase**. The first burst should produce a central image, the second burst should not. If these are the wrong way around, one channel in your system is phase inverted. Press the ◀ or ▶ button to stop the test and return to the menu.

Burn In



A procedure to condition your system. The unit displays **Burn In Caution! Loud**, then outputs modulated pink noise that ramps up and down slowly in level. Press the **Menu** or ◀ or ▶ buttons to stop the procedure.



Please ensure that the volume level is reasonable, as careless use of the **Burn In** feature can damage your amplifiers and loudspeakers. dCS will not be liable for such damage.

SPECIFICATION

Digital inputs	<p>UPnP Network interface on an RJ45 connector streams music files from a NAS or local computer over an Ethernet network. Supported file formats are:</p> <ul style="list-style-type: none"> • FLAC, AIFF, WAV & M4a – up to 24 bit PCM at 44.1, 48, 88.2, 96, 176.4 192, 352.8 or 384kS/s. • ALAC, MP3 & OGG - up to 24 bit PCM at 44.1 or 48kS/s. • DSD/64 or DSD/128 files can be streamed in DFF/DSF & DoP formats. <p>The interface will accept audio data streamed from an iPad, iPod or iPhone (which are currently limited to 44.1 or 48kS/s) via Apple AirPlay.</p> <p>The Network interface operates in Asynchronous mode.</p>
	<p>USB1 interface on a B-type connector, will accept up to 24 bit PCM at:</p> <ul style="list-style-type: none"> • 44.1, 48, 88.2 or 96kS/s when set to USB Class 1 (no driver required). • 44.1, 48, 88.2, 96, 176.4, 192, 352.8 or 384kS/s when set to USB Class 2 (no special driver is required for OSX 10.6.3 onwards, load the latest <i>dCS</i> USB Class 2 driver for Windows). • In USB Class 2 mode, passes through DSD/64 or DSD/128 in DoP format. <p>The USB1 interface operates in Asynchronous USB mode.</p>
	<p>USB2 interface on A-type connector, streams audio files from a USB flash drive up to 24 bit PCM at 44.1, 48, 88.2, 96, 176.4, 192, 352.8 or 384kS/s plus DSD/64 or DSD/128.</p> <p>The USB2 interface operates in Asynchronous USB mode.</p>
	<p>AES3 on a 3-pin female XLR connector, will accept up to 24 bit PCM at 32, 44.1, 48, 88.2, 96, 176.4 or 192kS/s or DSD/64 in DoP format.</p>
	<p>3x SPDIF on 2x RCA Phono and 1x BNC connectors. Each will accept up to 24 bit PCM at 32, 44.1, 48, 88.2, 96, 176.4 or 192kS/s or DSD/64 in DoP format.</p>
	<p>Optical SPDIF on TosLink connector, will accept up to 24 bit PCM at 32, 44.1, 48, 88.2 or 96kS/s.</p>
	<p>1x SDIF-2 interface on 2x BNC connectors, will accept up to 24 bit PCM at 32, 44.1, 48, 88.2 or 96kS/s or SDIF-2 DSD/64 (auto-selected). This interface requires a compatible word clock connected to one of the Word Clock Inputs, locked to the data rate.</p>
Digital outputs	<p>2x AES3 on 3-pin female XLR connectors. Each outputs 24 bit PCM at 32, 44.1, 48, 88.2, 96, 176.4 or 192kS/s or DSD/64 in DoP format,</p> <p style="text-align: center;">-OR-</p> <p>used as a Dual AES pair at 88.2, 96, 176.4, 192, 352.8 or 384kS/s or DSD/64 or DSD/128 in DoP format.</p>
	<p>2x SPDIF on 1x RCA Phono and 1x BNC connectors. Each outputs 24 bit PCM at 32, 44.1, 48, 88.2, 96, 176.4 or 192kS/s or DSD/64 in DoP format.</p>
	<p>2x SPDIF on 2x RCA Phono and 1x BNC connectors. Each outputs 24 bit PCM at 32, 44.1, 48, 88.2, 96, 176.4 or 192kS/s or DSD/64 in DoP format.</p>

Clocking	<p>2x Word Clock Inputs on 2x BNC connector, accepts standard word clock at 32, 44.1, 48, 88.2, 96, 176.4 or 192kHz. The data rate can be the same as the clock rate or an exact multiple (such as 0.25x, 0.5x, 1x, 2x, 4x, 8x) of the clock rate. Sensitive to TTL levels.</p> <p>The Word Clock Inputs will also accept 38.4kHz word clock from a Vivaldi DAC set to Universal Master Mode.</p> <p>Word Clock Output on 1x BNC connector, outputs standard word clock at a frequency equal to the (single wire) output data rate, or 44.1kHz when set to output DSD.</p>
Upsampling rates	<p>Data from any input may be converted to 24 bit PCM at 32, 44.1, 48, 88.2, 96, 176.4, 192, 352.8 or 384kS/s or DSD (1 bit data at 2.822MS/s) or DSDx2 (1 bit data at 5.644MS/s). The output sample rate must be equal to or greater than the input sample rate. The supported combinations are listed in the table on page 34.</p>
Spurious responses	<p>Better than -100dB0, 20Hz-20kHz</p>
Optional filters	<p>A choice of filters is available for 12 popular conversions, see page 34 for details.</p>
Size and weight	<p>444mm (17.5") long x 435mm (17.2") deep x 125mm (5.0") high, excluding cable connectors. Allow space for air flow around the unit.</p> <p>14.2kg (31.3lbs).</p>
Power requirements	<p>Internally set to either 100, 115/120, 220 or 230/240V AC, 50/60Hz.</p> <p>Power consumption: 15W typical, 50W maximum.</p> <p>Consumes less than 0.5W when powered down from the front panel.</p>

These specifications are subject to change without notice.

MAINTENANCE AND SUPPORT

Service and Maintenance

dCS audio products are designed not to need regular maintenance, and contain no user serviceable parts apart from the mains fuse. If your unit is damaged in any way, please contact your dealer.

Replacing a Blown Mains Fuse

There is a mains fuse below the power inlet, accessible from the outside of the unit. If the fuse blows, it may be changed by the user. The current consumption of the unit is very low, so it only blows if power surges occur, or there is a fault in the unit. Usually power surges cause no other damage, but if the fuse blows repeatedly on replacement, some other damage will have been done and the unit must be returned to dCS for repair.

Fuse type: 20 x 5mm T 1 amp L fuse



If the fuse should fail, it is essential that it is replaced with one of the same type and rating. Failure to do so could result in damage to the unit, risk of fire or electric shock and will invalidate the warranty. Fuse failure is rare!

Referring to the diagram below, remove the power cable, use your fingernails to catch the two tabs of the fuse holder (A), push them together to release the clips and pull the fuse holder out. Pull out the blown fuse from the lower position (B) and discard it. Either move the Spare Fuse (C) to the lower position or fit one of the fuses from the manual pack. Orient the fuse holder as shown (D) and push the holder back into the power inlet so that it clicks home.

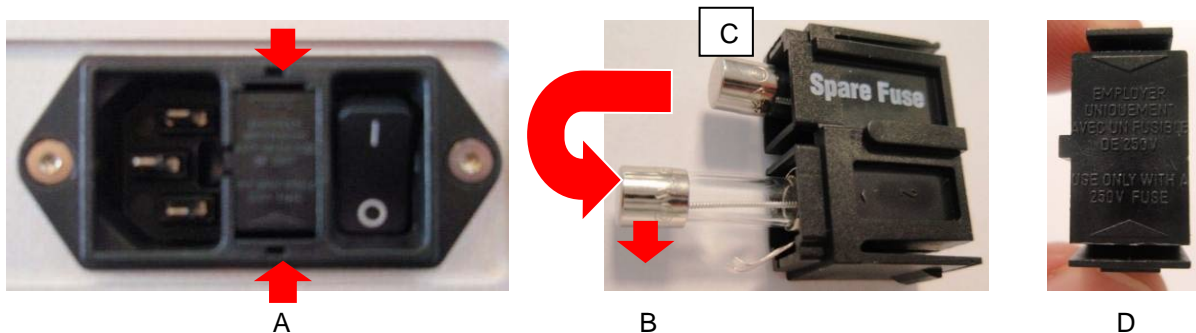

Cleaning the case

The front and back panels of your dCS equipment are machined from very high grade aluminium. Great care has been taken to create the finish of the aluminium throughout the engineering process from the raw solid material to the finished piece.

To remove loose dust or finger marks from the case, we recommend that you use a clean, dry, lint-free cloth.

To restore the finish, we recommend applying small quantities of a lanolin based cleaner, using a clean, dry, lint-free cloth and then wiping off. Do not allow lanolin to collect around the buttons.

Small amounts of glass cleaner containing ammonia may be used to clean other surfaces, but avoid spraying onto the connector contacts.

Limited Warranty

General

dCS warrants this product against defects in materials and workmanship for a period of 3 years from the date the unit was originally shipped from dCS. If the product is purchased and registered with dCS within 6 months of the date the unit was originally shipped from dCS, we will start the warranty on the purchase date. For units registered later than 6 months from the ship date, we will start the warranty from the ship date unless the registration is supported by the original sales invoice. During the warranty period, dCS will repair or, at our absolute discretion, replace a faulty product. Warranty repairs must only be carried out by dCS or our authorised service agents. Please contact your dealer if your unit requires service.

To register this product, either register online at www.dcsLtd.co.uk or complete the **Product Registration** form within 30 days of the sale and return it to dCS. On receipt of the registration, dCS will add your contact details to our customer database. dCS will use this information for warranty purposes only, we will not contact you directly for reasons relating to sales and marketing.

This warranty applies to the original owner, it is not transferable.

Warranty Exclusions

The Warranty does not cover wear and tear.

The Warranty on this product will be void if:

- the product is misused in any way.
- any unauthorised modifications or repairs are carried out.
- the product is not used in accordance with the Operating Conditions stated in this manual.
- the product is serviced or repaired other than by dCS or our authorised service agents.
- the product is operated without a mains earth (or ground) connection.
- the unit is returned inadequately packed.

dCS reserve the right to apply a service charge if a product returned for warranty repair is found to be operating correctly, or if a product is returned without a returns number being issued.

This warranty covers parts and labour only, it does not cover shipping charges or tax/duty.

Our dealers or distributors are NOT authorised to extend the terms of this warranty, dCS cannot accept responsibility for any attempt to do so.

Products re-sold by dCS on a "used" basis may be subject to reduced warranty terms.

Obtaining Service

Should you encounter a problem, contact your authorised dCS dealer for advice, quoting the model, the full serial number, software version number, and giving a detailed description of the fault. Your dealer will advise you fully on actions that need to be taken. When returning a unit, the original packaging should be used to avoid transit damage. Replacement packaging sets may be purchased from dCS.

During the Warranty period, there will normally be no charge for parts or labour.

Operating Conditions

- The supply voltage must remain within +/-10% of the A.C. voltage specified on the back panel.
- The supply frequency must be in the range 49Hz to 62Hz.
- Ambient temperature range: 0°C (32°F) to 45°C (113°F), non-condensing.
- Do not install the unit near heat sources such as radiators, air ducts, power amplifiers or direct strong sunlight.
- If in doubt, the easy test is – the unit is happy to work anywhere a human is.

If you need more help

In the first instance, you should contact your dealer. If they cannot resolve the issue, contact your national distributor.



dCS, our dealers and distributors cannot accept responsibility for I.T. support issues. In such cases, please ask the computer or software vendor for advice.

Manufactured by:

Data Conversion Systems Ltd.
Unit 1, Buckingway Business Park,
Anderson Road,
Swavesey,
Cambridgeshire. CB24 4AE
UK

www.dcsLtd.co.uk

This user manual may be downloaded free of charge from our web-site. A bound copy of this manual may be ordered from *dCS*.

Software History

dCS products make extensive use of software configurable chips – FPGAs and DSPs. This gives us the ability to update our products to add extra features, update digital interface standards or make performance improvements by loading new software. Occasionally, a hardware update may be necessary also to increase the “capacity” of the electronics, add extra connectors or extra front panel controls.

Please note that not all software updates produce an audible improvement. We recommend that you keep your software up to date. Check the dCS web-site occasionally for news of the latest software updates.



Update discs are available from our distributors. Before requesting an update disc, please open the **Info > Version** menu page and check the **Control Board** version to verify that an update is actually needed.

This manual is for Vivaldi Upsampler software version 2.0x.

Issue 1.00	The first issue, hardware type VUP .
Issue 1.01	Reliability improvement.
Issue 1.02 / Network v56	Integrates the Upsampler with the dCS Apps for iPad & iPhone/iPod, adds extra RS232 commands, corrects a Network Update bug.
Issue 1.10 / Network v57	<p>Configuration menu added, with Settings Lock, Save & Restore Configuration. DXD Lock and DSD Pass features added to the Settings menu.</p> <p>Inputs that are not connected and active cannot be selected.</p> <p>The USB1 input accepts 24-bit data at 352.8 and 384kS/s.</p> <p>New conversions added: 352.8 > DSD, DSD > 176.4 / 192 / 352.8 / 384kS/s.</p> <p>Support for the EasyPlay feature added to all outputs.</p> <p>Support for the Vivaldi DAC's Universal Master Mode added.</p> <p>The Upsampler mutes the outputs when the Non-Audio flag is set in the incoming data.</p> <p>RS232 commands added for Sleep, Wake, Power Down, Set Sync Mode, report Input Sample Rates 176.4, 192, 352.8, 384kS/s & DSD.</p> <p>Improved IR remote control of USB2 browser & generally improved browser operation.</p> <p>Improve responsiveness of front panel controls when playing back from iPod.</p> <p>Factory Reset turns the Display On.</p> <p>USB2, iPod & Network inputs can be renamed.</p> <p>Provision for renaming the inputs via the App added.</p> <p>Various minor bugs fixed.</p>
Issue 1.20 / Network v63	<p>Network and USB2 inputs can stream DFF/DSF DSD/64 files.</p> <p>More RS232 Text mode commands added.</p>

Software version 2.00 onwards is compatible with hardware type **VPP**, it will not run on VUP units. VPP features a new network streaming board, with galvanically isolated Network and USB1 interfaces.

Issue 2.01 / Network 307	<p>Network, USB and Dual AES interfaces support DSD/128 (DSDx2).</p> <p>Extra conversions added: 32 - DSDx2 > DSDx2, 176.4 – 352.8 > DSDx2. There are 6 filters for 44.1 > DSDx2, 1 filter for the other new conversions.</p> <p>Improved RS232 integration.</p> <p>iPod input deleted, mobile devices play via AirPlay instead.</p> <p>USB2 input is now accessed as part of the Network interface, not as a separate input.</p> <p>EasyPlay feature added to the Settings menu.</p> <p>Support for Vivaldi 2.0 control app added, using a 3-way RS232 link.</p> <p>Roon Ready.</p>
--------------------------	---

A		G		power off..... 34
AES input..... 10, 36		generator menu 46		power up..... 9, 34
AES output 12, 36		I		R
AirPlay 25		information menu..... 41		rear panel 36
app..... 19		input		remote control 33, 38
app remote control..... 26		AES..... 10, 36		remote control app 26
B		disabled..... 35		rename device 31
bit perfect..... 43		network 18, 37		rename input 32
browser 28		rename 32		reset..... 45
close..... 34		sample rates 36		input names 32, 45
navigate up 35		SDIF-2..... 10, 36		restore configuration..... 45
scroll down 35		SPDIF 10, 36		Roon Ready 25
scroll up..... 35		Toslink..... 10, 36		RS232..... 38, 44
start 34		USB1..... 15, 38		S
burn in..... 46		USB2..... 28, 38		safety 6, 7
C		word clock..... 37		save configuration 45
cables 9		input button..... 35		SDIF-2 input 10, 36
channel check..... 46		L		serial number..... 38, 41
cleaning 49		lock 45		service 49
clock frequencies..... 37		M		settings menu 42
clone mode 43		master clock 13, 30		setup guide..... 9
compatibility		menu..... 39		sleep 34
operating systems.. 15, 38		close..... 34		software 41, 52
UPnP control point..... 18		configuration 45		SPDIF input 10, 36
configuration		display..... 46		SPDIF output..... 12, 36
menu 45		generator..... 46		specification..... 47
restore..... 45		information 41		Spotify..... 25
save..... 45		settings..... 42		status 41
contact 41		menu back button 35		sync mode 13, 19, 29, 30, 42
D		menu button..... 34		T
display..... 33		menu forward button 35		Tidal..... 25
brightness 46		menu, using..... 40		Toslink input 10, 36
NA 33		N		U
network, USB2 33		NAS drive 18		update..... 31, 41, 52
off 46		network		UPnP 18, 37
display menu 46		input 18, 37		USB
DSD pass through 43		setup 18		class..... 15, 43
Dual AES output.. 11, 36, 42		O		Windows driver 15
DXD display 44		operating conditions 50		USB1 input 15, 38
DXD mode 35, 44		output		USB2 input 28, 38
E		AES..... 12, 36		V
EasyPlay..... 44		Dual AES 11, 36		version 41
enhanced clocking..... 13		sample rates 36		voltage..... 38
F		SPDIF 12, 36		W
feet..... 5		word clock..... 37		wake 34
filter 1 only? 34		output button..... 35		warranty..... 50
filter button 34		P		web client 31
filter choices..... 34		PC setup..... 16		word clock 13, 30
flash drive 28		phase check 46		word clock input..... 37
front panel..... 33		positioning 5		
fuse, replacing 49		power button..... 34		

Network Information Sheet

Name:	Date:
-------	-------



**PLEASE TREAT THE INFORMATION ON THIS PAGE AS CONFIDENTIAL!
KEEP IT SAFE, AS YOU MAY NEED TO REFER TO IT IN THE FUTURE.**

ISP Information

Current ISP		Account No.	
Login		Password	
ISP support tel.			
Router model		Backup loc.	
Router login		Password	
LAN Gateway		Subnet mask	
DHCP block from		...to	

Wireless Network Information

SSID		Encryption	
		Passkey	
WAP 1 location		Channel	
WAP 2 location		Channel	
WAP 3 location		Channel	

Infrastructure Device Information

Device Name	Static IP?	Dyn IP?	MAC address	Login	Password
		Y / N			
		Y / N			
		Y / N			
		Y / N			
		Y / N			
		Y / N			
		Y / N			
		Y / N			