

# Luma

Spring Roller Operated  
Projection Screen

by **DRAPER**

## Specifications—Luma

\_\_\_\_\_ projection screens, size \_\_\_\_\_ h.  
x \_\_\_\_\_ w., wall/ceiling mounting. Case of 22 ga. steel, flat back design, with scratch-resistant white polyester finish. Friction-free closure. Viewing surface shall be flame and mildew resistant.



Matt White XT1000E and Contrast Grey XH800E viewing surfaces are certified to GREENGUARD standards for low chemical emissions into indoor air during product usage. For more information, visit [ul.com/gg](http://ul.com/gg). Endcaps finished to match case, with integral roller brackets, concealing roller ends. With matching universal mounting brackets. Fabric securely attached to one-piece rigid steel roller. Bottom of viewing surface attached to weighted dowel. Saddle and pull attached by screws. Specifications subject to change without notice.

### Please Check All Appropriate Selections

#### Select Viewing Surface:

- Matt White XT1000E (1.0 gain): GREENGUARD Gold certified
- Argent White XH1500E (1.5 gain): Optional
- Contrast Grey XH800E (0.8 gain): GREENGUARD Gold certified: Optional
- Other: \_\_\_\_\_

#### Optional Accessories:

- Mounting Brackets
    - 6" Brackets
    - 10"/14" Brackets
    - Adjustable Brackets
  - T-Bar Twist Clips (Not recommended for screens over 70" x 70")
  - Magnetic Tilt Lock Mechanism
  - Wall Tie-Back
  - Extra Screen Drop <sup>1</sup>
    - Same color as viewing surface (standard on AV format screens)
    - Black (standard on other formats)
- Length of total drop (including standard 12" on some sizes—see grid at right) <sup>1</sup> \_\_\_\_\_
- Black Masking Borders (1½" wide on sizes through 70" wide; 1¾" on 84" wide; 2" wide on larger sizes) (optional on AV format screens; standard on all others)

### Optional Mounting Brackets

6" Brackets

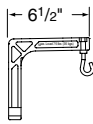

10-14" Brackets

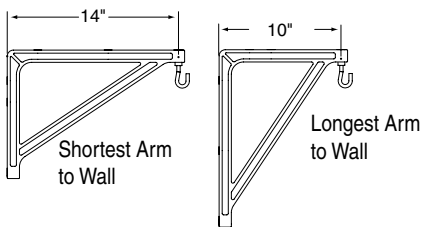

Adjustable Brackets

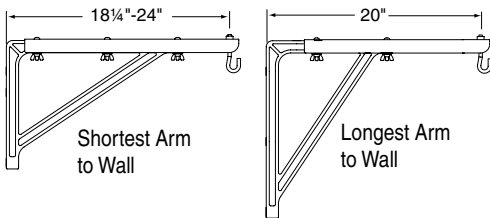

### Dimensions & Data

Size H x W	Case Length	Net Wt. (lbs.)	Qty.		
<b>AV Format</b>					
50" x 50"	52 <sup>3</sup> / <sub>8</sub> "	9			
60" x 60"	62 <sup>3</sup> / <sub>8</sub> "	11			
70" x 70"	72 <sup>3</sup> / <sub>8</sub> "	15			
84" x 84"	86 <sup>3</sup> / <sub>8</sub> "	20			
72" x 96"	98 <sup>3</sup> / <sub>8</sub> "	23			
96" x 96"	98 <sup>3</sup> / <sub>8</sub> "	25			
Nominal Diagonal	Image Area	Overall Size	Case Length	Net Wt. (lbs.)	Qty.
<b>NTSC Video Format (4:3)</b>					
6'	42½" x 56½"	46½" x 59½"	62 <sup>3</sup> / <sub>8</sub> "	11	
7'	50" x 66½"	53½" x 69½"	72 <sup>3</sup> / <sub>8</sub> "	14	
100"	60" x 80"	64" x 83½"	86 <sup>3</sup> / <sub>8</sub> "	17	
10'	69" x 92"	73" x 96"	98 <sup>3</sup> / <sub>8</sub> "	21	
<b>HDTV Format (16:9)</b>					
65" <sup>1</sup>	31¾" x 56½"	43¾" x 59½"	62 <sup>3</sup> / <sub>8</sub> "	11	
73" <sup>1</sup>	36" x 64"	48" x 69½"	72 <sup>3</sup> / <sub>8</sub> "	14	
82" <sup>1</sup>	40½" x 72"	52½" x 74"	76 <sup>3</sup> / <sub>8</sub> "	17	
92" <sup>1</sup>	45" x 80"	57" x 83½"	86 <sup>3</sup> / <sub>8</sub> "	19	
100" <sup>1</sup>	49" x 87"	61" x 91"	93 <sup>3</sup> / <sub>8</sub> "	23	
106" <sup>1</sup>	52" x 92"	64" x 96"	98 <sup>3</sup> / <sub>8</sub> "	23	
<b>16:10 Format</b>					
67" <sup>1</sup>	35¼" x 56½"	47¼" x 59½"	62 <sup>3</sup> / <sub>8</sub> "	11	
76" <sup>1</sup>	40" x 64"	52" x 69½"	72 <sup>3</sup> / <sub>8</sub> "	14	
85" <sup>1</sup>	45" x 72"	57" x 74"	76 <sup>3</sup> / <sub>8</sub> "	17	
94" <sup>1</sup>	50" x 80"	62" x 83½"	86 <sup>3</sup> / <sub>8</sub> "	19	
109" <sup>1</sup>	57½" x 92"	69½" x 96"	98 <sup>3</sup> / <sub>8</sub> "	23	
<b>Custom Size</b>					

<sup>1</sup> These sizes include 12" black drop as standard.

Case height—4<sup>3</sup>/<sub>4</sub>"

Case width—3<sup>3</sup>/<sub>16</sub>"

Case length = viewing surface overall width + 2<sup>7</sup>/<sub>8</sub>".

15:9 and 1.85:1 Formats also available.

### Methods Of Installation (Hardware by others)

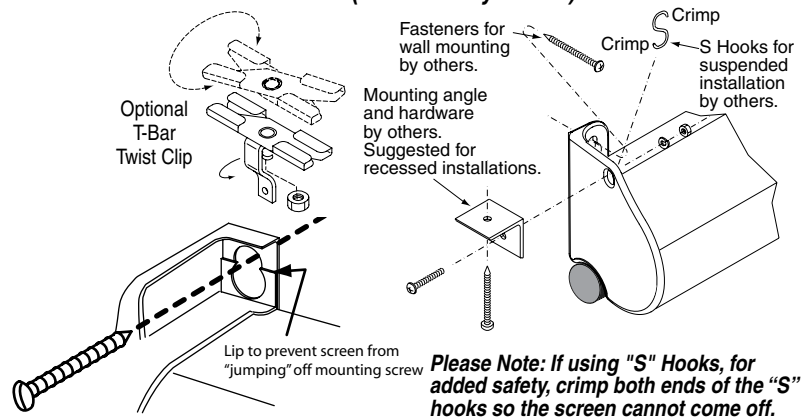

**DRAPER**

411 S. Pearl St., Spiceland, IN 47385 USA ■ 765-987-7999  
www.draperinc.com ■ fax 765-987-7142

Copyright © 2015 Draper Inc. Form Luma\_Sub15 Printed in U.S.A.

PROJECT: \_\_\_\_\_

ARCHITECT: \_\_\_\_\_

CONTRACTOR: \_\_\_\_\_

SUPPLIER: \_\_\_\_\_

DATE: \_\_\_\_\_ REVISED: \_\_\_\_\_